

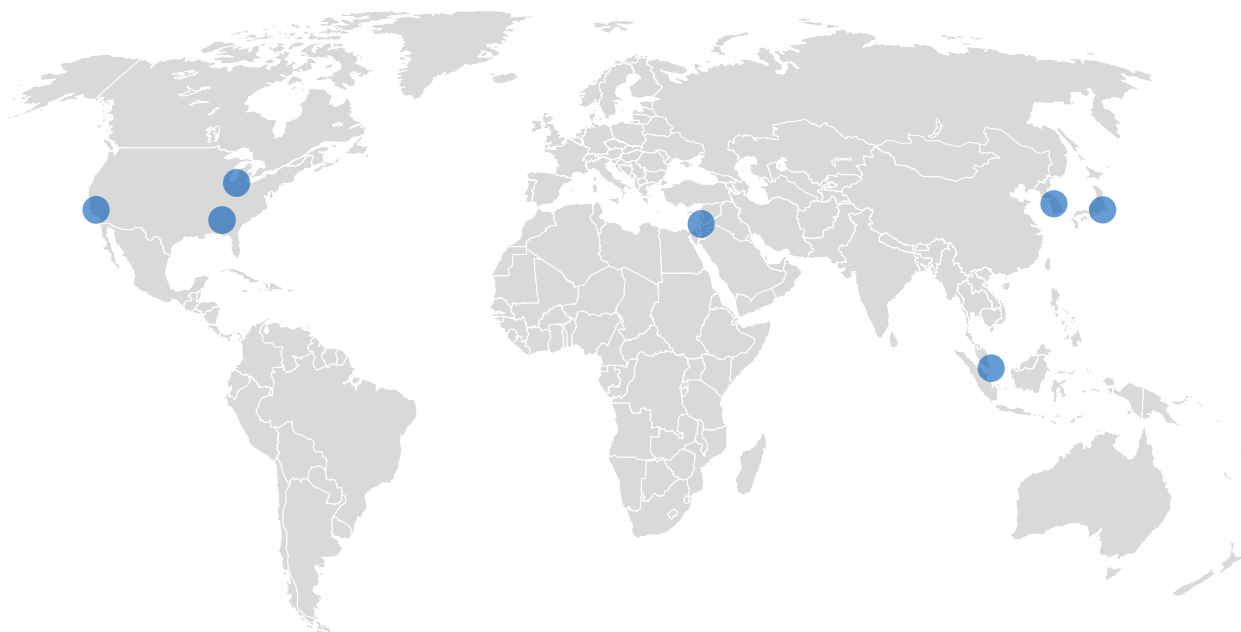

F-Theta Sales Guide 01/2025

High-Precision F-Theta Objective Lenses for Laser Material Processing

We are there for you.
Worldwide.



Europe

JENOPTIK Optical Systems GmbH
Goeschwitzer Strasse 25
07745 Jena · Germany
www.jenoptik.com/optics

Ms. Ina Rocktäschel
ina.rocktaeschel@jenoptik.com
Phone +49 3641 65-3234

North America

Mr. Jim Volek
jim.volek@jenoptik.com

JENOPTIK Optical Systems, LLC.
38300 Civic Center Drive, Suite 240
Fremont · VA 94538 · USA
Phone: +1 561 881 7400

Israel

Mr. Vladislav Gvardiyan
vladislav.gvardiyan@jenoptik.com

Branch Office Israel
Einstein Street 16
76470 Nees Ziona
Phone: +972 8 930 3501

China

Mr. Robin Bai
robin.bai@jenoptik.com

JENOPTIK (Shanghai) Precision
Instrument and Equipment Co., Ltd.
Building 15, No. 3999 Xiupi Road
201315 Shanghai
Phone: +86 21 3825-2380

Japan

Ms. Yuko Tanaka
yuka.tanaka@jenoptik.com

JENOPTIK Japan Co., Ltd.
2-3-8 Shin-Yokohoma, Kohoku-Ku,
Yokohoma, Kanagawa 222-0033
Phone: +81 45 670-9140

Korea

Mr. Cavin Kim
changhwan.kim@jenoptik.com

JENOPTIK Korea Corporation, Ltd.
91, Hyeongoksandan-ro 93 beon-gil,
Cheongbuk-myeon, Pyeongtaek-si,
Gyeonggi-do, 17812 Pyeongtaek City
Phone: +82 10 3753-2503

South East Asia

Mr. Dennis Yeh
dennis.yeh@jenoptik.com

JENOPTIK Asia Pacific Pte., Ltd.
20 Harbour Drive PSA Vista
#05-06A, Singapore 117612
Phone: +65 6774 0479-115

Find the right fit – Jenoptik F-Theta product families

F-Theta JENar™ Silverline™ – Fused silica high-power objective lenses

The Silverline™ F-Theta objective lenses from Jenoptik have been specially developed for applications that require high-power lasers and short-term pulses. Lenses of that series consist of low-absorbing, full quartz glass to fit particularly high-power laser applications. You will find a wide variety of F-Thetas – for wavelengths of 266 nm, 355 nm, 1030...1080 nm or 900...1100 nm.

The Silverline™ F-Theta lenses limit diffraction and produce a high image quality. They are also highly resistant to damage and provide high spot consistency over the entire scanning range. With beam power of up to four kilowatts, the Silverline™ lenses do not require active cooling and guarantee a minimal focal point shift for high-power lasers.



F-Theta JENar™ APTAline™ – Focused on the essentials and application-tailored

With the JENar™ APTAline™ series, Jenoptik offers F-Theta objective lenses that are optimally tailored to customers' requirements. In this way Jenoptik responds to the constantly changing requirements of the industry and increase the possible range of applications with the APTAline™ series.

These quartz glass, high-power lenses offer a cost-optimized alternative for demanding applications where reliability, series stability and durability count. They are available for wavelengths of 355 to 1030...1080 nm. The APTAline™ objective lenses are based on proven mechanical and optical designs and are subject to the same high-quality standards as other F-Theta products of Jenoptik.



F-Theta JENar™ – Reliable all-rounders for a wide range of laser applications

The F-Theta JENar™ lenses are suitable for uses in micromaterial processing, especially for micro structuring or for marking and labeling different materials.

The JENar™ series is used for laser wavelengths in the UV, VIS or IR range, but they are also available for wavelengths from 530 to 1080 nm. The standard lenses are produced with protective glass and are extremely durable.

These lenses can be quickly and easily integrated into any system using the available STEP files. Each lens undergoes a standardized application-specific test, which ensures consistency of the optical properties during series production. This makes it easy to replace lenses, and customer benefit from an increased product lifecycle.



F-Theta JENar™ Lens Series

Technical Parameters & Properties overview

Focal Length	Scan Field Diagonal	Max. Full Diagonal Scan Angle	Max. Input Beam Diameter for 2-axis-scan	Focus Size at 1/e ² Intensity Level	a1 a2 Recomm. Mirror Separation 2nd Mirror to Flange	Telecentricity only F-Theta with Scanner	Back Working Distance from last mechanical surface (incl. window)	Window Order Number for Spare Part	Mounting Thread	Lens Order Number
--------------	---------------------	-------------------------------	--	--	---	--	---	------------------------------------	-----------------	-------------------

Wavelength 1030...1080 nm; T@500...680 nm > 85% (VIS*)

125 mm	80 mm	37°	15 mm	16 μm	18 mm 38 mm	4.9° 5.1°	155 mm	602019	M85x1	601926*
160 mm	170 mm	60°	10 mm	31 μm	13 mm 43 mm	17.1° 17.2°	178 mm	576234	M85x1	601914*
255 mm	239 mm	53°	20 mm	24 μm	25 mm 39 mm	14.3° 15.0°	291 mm	602019	M85x1	601948*

Wavelength 1030...1080 nm

100 mm	93 mm	54°	10 mm	19 μm	13 mm 43 mm	8.7° 9.1°	87 mm	576230	M85x1	017700-024-26
125 mm	80 mm	37°	15 mm	16 μm	18 mm 38 mm	4.9° 5.1°	155 mm	575267	M85x1	017700-003-26
160 mm	170 mm	60°	10 mm	31 μm	13 mm 43 mm	17.1° 17.2°	178 mm	576230	M85x1	017700-019-26
170 mm	170 mm	57°	14 mm	24 μm	17 mm 41 mm	11.6° 11.7°	194 mm	575267	M85x1	017700-018-26
255 mm	239 mm	53°	20 mm	24 μm	25 mm 39 mm	14.3° 15.0°	291 mm	575267	M85x1	017700-017-26
347 mm	355 mm	58°	15 mm	46 μm	17 mm 41 mm	18.2° 18.2°	404 mm	575267	M85x1	609661
347 mm	354 mm	57.6°	16 mm	46 μm	17 mm 40.5 mm	18.7° 18.7°	403.8 mm	575267	M85x1	017700-022-26
350 mm	452 mm	71°	15 mm	45 μm	13 mm 25 mm	23.7° 24.0°	395 mm	610826	M85x1	017700-009-26
420 mm	420 mm	57°	15 mm	55 μm	17 mm 41 mm	18.7° 18.8°	501 mm	575267	M85x1	017700-021-26

Wavelength 515...540 nm

100 mm	90 mm	53°	10 mm	10 μm	13 mm 43 mm	7.7° 7.8°	95 mm	576232	M85x1	017700-209-26
102 mm	75 mm	43°	15 mm	7 μm	18 mm 36 mm	4.1° 4.9°	132.9 mm	576228	M85x1	017700-202-26
108 mm	75 mm	40°	15 mm	7 μm	16 mm 39 mm	4.9° 5.1°	130 mm	599379	M85x1	017700-203-26
170 mm	160 mm	54°	14 mm	12 μm	17 mm 41 mm	10.9° 11.0°	195 mm	576228	M85x1	017700-206-26
255 mm	233 mm	52°	20 mm	12 μm	25 mm 39 mm	14.2° 14.3°	294 mm	576228	M85x1	017700-205-26
330 mm	347 mm	58°	16 mm	23 μm	17 mm 41 mm	18.4° 18.4°	384 mm	576228	M85x1	017700-208-26
420 mm	420 mm	57°	15 mm	27 μm	17 mm 41 mm	19.3° 19.3°	485 mm	576228	M85x1	017700-207-26



Definition of parameters

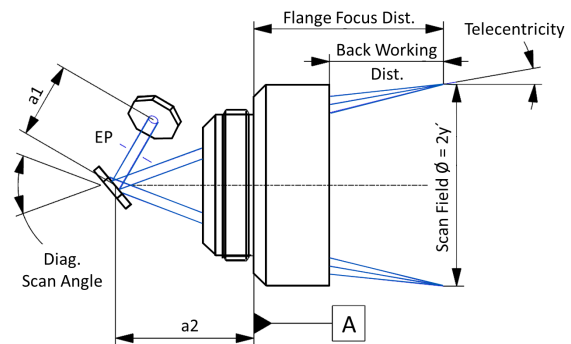

The data given are nominal values for the specified application parameters. Jenoptik provides Zemax® BlackBox files for simulating application results for customized parameters (e.g. wavelength, scanner geometry, beam diameter, ...). In case of different optical setups please contact us to tune your system. Back working distance, flange focus distance, and focal length vary by ± 1.5 % due to manufacturing variances.

JENar™: Registered in EU, CN, JP, SG, US | Silverline™: Registered in DE, JP, SG, IN | F-Theta: Registered Design in EU, CN, KR, IN, SG, JP, HK, TW

It is our policy to constantly improve the design and specifications. Accordingly, the details represented herein cannot be regarded as final and binding.

F-Theta JENar™ Silverline™ Lens Series

Technical Parameters & Properties overview

Focal Length	Scan Field Diagonal	Max. Full Diagonal Scan Angle	Max. Input Beam Diameter for 2-axis-scan	Focus Size at 1/e ² Intensity Level	a1 a2 Recomm. Mirror Separation 2nd Mirror to Flange	Telecentricity only F-Theta with Scanner	Back Working Distance from last mechanical surface (incl. window)	Window Order Number for Spare Part	Mounting Thread	Lens Order Number
Wavelength 1030...1080 nm										
160 mm	110 mm	40°	14 mm	22 μm	17 mm 40 mm	5.2° 5.4°	184 mm	576225	M85x1	017700-025-26
161 mm	71 mm	12.7°	14 mm	23 μm	17 mm 40 mm	4.1° 4.2°	153 mm	666277	M85x1	660149
255 mm	160 mm	36°	20 mm	25 μm	25 mm 48 mm	7.2° 7.4°	303 mm	576225	M85x1	017700-026-26
423 mm	360 mm	48°	14 mm	59 μm	17 mm 40 mm	16.4° 16.4°	500 mm	629206	M85x1	609120
Wavelength 900...1100 nm										
160 mm	110 mm	40°	14 mm	19 μm	17 mm 40 mm	5.2° 5.4°	182 mm	602021	M85x1	601787
255 mm	160 mm	36°	20 mm	21 μm	25 mm 48 mm	7.2° 7.4°	302 mm	602021	M85x1	601804
423 mm	360 mm	48°	14 mm	50 μm	17 mm 40 mm	16.4° 16.4°	500 mm	628981	M85x1	628951
Wavelength 515...540 nm										
115 mm	71 mm	36°	14 mm	8 μm	17 mm 40 mm	3.5° 3.7°	146 mm	628062	M85x1	624103
163 mm	92 mm	16.4°	12 mm	14 μm	17 mm 49 mm	0.4° 1.0°	235 mm	660158	M85x1	659612
330 mm	332 mm	27.6°	16 mm	21 μm	19 mm 50 mm	23.5° 23.5°	216 mm	674648	M102x1	663834
Wavelength 355 nm										
55 mm	22 mm	23°	6 mm	6 μm	13 mm 46 mm	0.8° 1.6°	60 mm	576243	M85x1	605678
55 mm	17 mm	17°	8 mm	4.5 μm	13 mm 46 mm	0.5° 1.1°	60 mm	576243	M85x1	605678
103 mm	71 mm	40°	9 mm	8 μm	14 mm 47 mm	2.4° 2.8°	135 mm	576239	M85x1	017700-402-26
125 mm	75 mm	18°	10 mm	8 μm	13 mm 42 mm	0.01° 0.97°	163 mm	641319	M85x1	628956
170 mm	140 mm	50°	10 mm	11 μm	13 mm 42 mm	4.8° 4.8°	236 mm	610829	M85x1	586840
255 mm	240 mm	54°	10 mm	17 μm	13 mm 42 mm	12.7° 12.7°	314 mm	579878	M85x1	017700-406-26
510 mm	464 mm	51°	14 mm	24 μm	14 mm 42 mm	18.2° 18.2°	609 mm	576241	M85x1	017700-405-26
Wavelength 266 nm										
103 mm	71 mm	40°	9 mm	6 μm	14 mm 46 mm	2.6° 2.9°	133 mm	610812	M85x1	017700-601-26

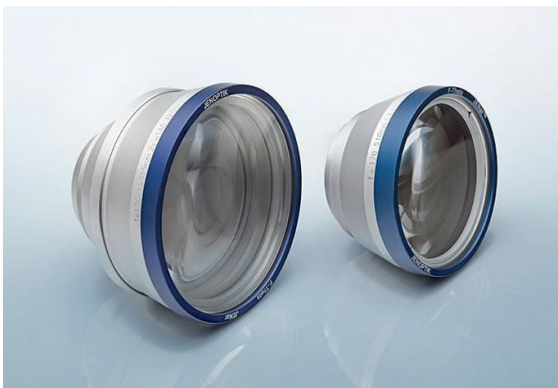

Definition of parameters

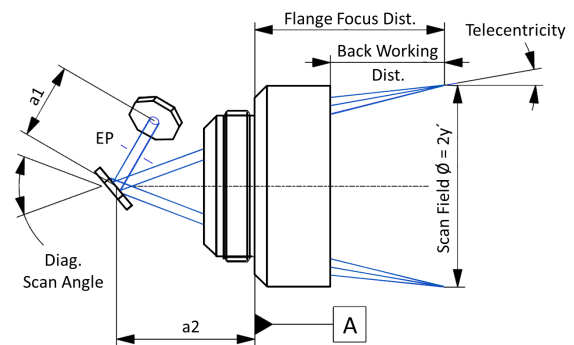

The data given are nominal values for the specified application parameters. Jenoptik provides Zemax® BlackBox files for simulating application results for customized parameters (e.g. wavelength, scanner geometry, beam diameter, ...). In case of different optical setups please contact us to tune your system. Back working distance, flange focus distance, and focal length vary by ± 1.5 % due to manufacturing variances.

JENar™: Registered in EU, CN, JP, SG, US | F-Theta: Registered Design in EU, CN, KR, IN, SG, JP, HK, TW

It is our policy to constantly improve the design and specifications. Accordingly, the details represented herein cannot be regarded as final and binding.

F-Theta JENar™ APTAline™ Lens Series

Technical Parameters & Properties overview

Focal Length	Scan Field Diagonal	Max. Full Diagonal Scan Angle	Max. Input Beam Diameter for 2-axis-scan	Focus Size at 1/e ² Intensity Level	a1 a2 Recomm. Mirror Separation 2nd Mirror to Flange	Telecentricity only F-Theta with Scanner	Back Working Distance from last mechanical surface (incl. window)	Window Order Number for Spare Part	Mounting Thread	Lens Order Number
Wavelength 1030...1080 nm (*VIS)										
160 mm	110 mm	40.0°	14 mm	22 μm	17 mm 40 mm	5.2° 5.4°	183 mm	691387	M85x1	689620
161 mm	71 mm	12.7°	14 mm	23 μm	17 mm 40 mm	4.1° 4.2°	153 mm	690809	M85x1	679781
255 mm	160 mm	36.0°	20 mm	25 μm	25 mm 48 mm	7.2° 7.4°	303 mm	576225	M85x1	689622
340 mm	255 mm	21.7°	20 mm	34.2 μm	26 mm 36 mm	11.6° 11.6°	484.7 mm	707589	M85x1	697568
340 mm	297 mm	25.4°	14 mm	48.6 μm	17 mm 35.5 mm	13.6° 13.7°	422.6 mm	707589	M85x1	697568
639 mm	580 mm	25.0°	20 mm	65.3 μm	25.6 mm 31.5 mm	22.3° 22.4°	565 mm	741117	M85x1	739662
675 mm	707 mm	28.4°	14 mm	79.09 μm	25 mm 40.5 mm	23.2° 23.2°	673.8 mm	696058	M110x1	666682*
Wavelength 515...540 nm										
429 mm	339 mm	22.8°	16 mm	26.9 μm	17 mm 32.5 mm	12.4° 12.4°	547.7 mm	740337	M85x1	739668
Wavelength 355 nm										
103 mm	71 mm	3.0°	9 mm	8 μm	14 mm 47 mm	2.4° 2.8°	135 mm	576239	M85x1	689627
340 mm	332 mm	27.0°	20 mm	11.8 μm	26.6 mm 46.2 mm	21.6° 21.7°	181.5 mm	703512	M102x1	663832
420 mm	353 mm	24.0°	15 mm	18.9 μm	17 mm 35.1 mm	14.7° 14.7°	496.0 mm	741118	M85x1	739569

*VIS



Definition of parameters

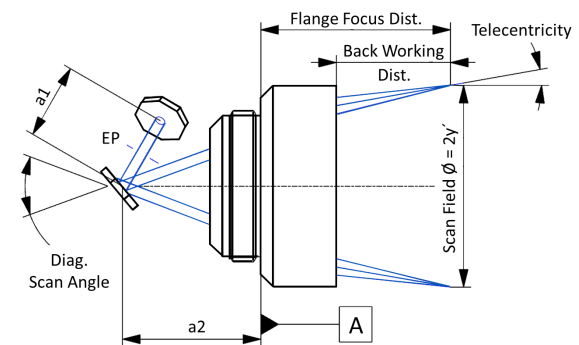

The data given are nominal values for the specified application parameters. Jenoptik provides Zemax® BlackBox files for simulating application results for customized parameters (e.g. wavelength, scanner geometry, beam diameter, ...). In case of different optical setups please contact us to tune your system. Back working distance, flange focus distance, and focal length vary by ± 1.5 % due to manufacturing variances.

JENar™ registered in: EU, CN, JP, SG, US | F-Theta: registered in: EU, CN KR, JP, SG, IN, HK, TW | APTAline™ registered in: DE, EU, JP, KR, US, CN

It is our policy to constantly improve the design and specifications. Accordingly, the details represented herein cannot be regarded as final and binding.

F-Theta JENar™ Lens Series

Telecentric Lens – JENar™ 125-1030...1080-80 + VIS

Parameters	JENar™ 125-1030...1080-80 + VIS Telecentric lens
Focal length:	125 mm
Wavelength:	1030...1080 nm; T@500...680 nm > 85 %
Scan field (X x Y); Ø:	(57 mm x 57 mm); 80 mm
Diagonal scan angle:	37.2°
Back working distance:	154.6 mm
Flange focus distance:	196.9 mm
Input beam Ø 1/e²:	15 mm
Focus size Ø 1/e²:	16 µm
a1:	18.2 mm
a2:	37.65 mm
Telecentricity (only F-Theta with scanner):	4.9° 5.1°
Group delay dispersion (GDD):	3670 fs²
LIDT coating pulsed; CW:	not available yet
LIDT system pulsed; CW:	not available yet
Weight:	0.86 kg
Order Number::	601926

Spot properties

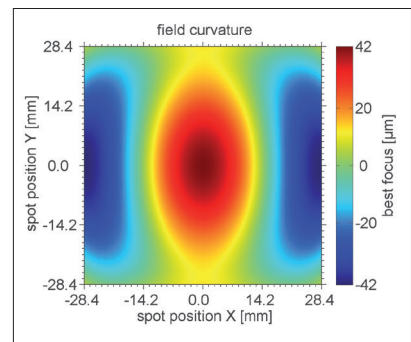
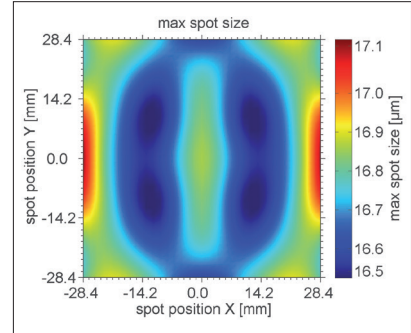

Specifications

JENar™ 125-1030...1080-80 + VIS

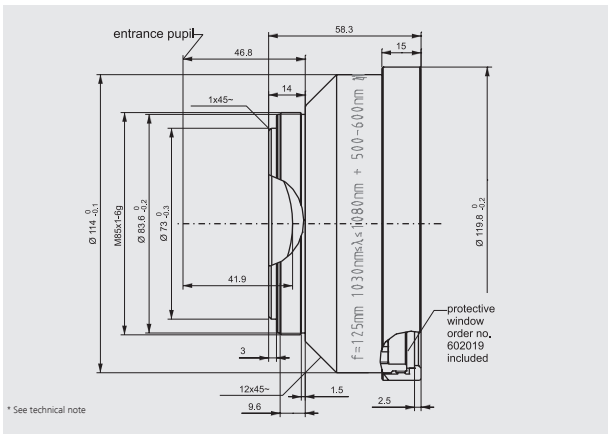

Definition of geometrical parameters

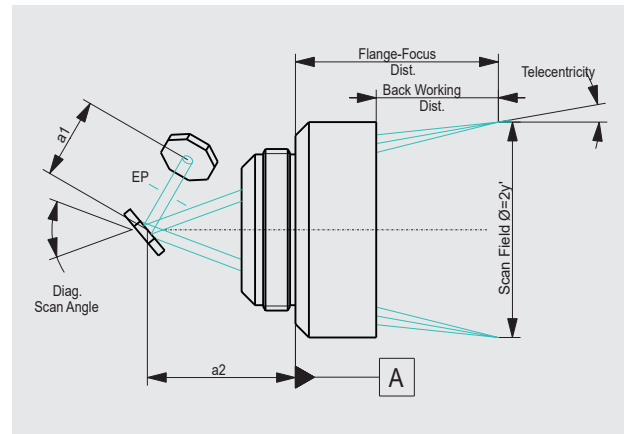

JENar™: Registered in EU, CN, JP, SG, US | F-Theta: Registered Design in EU, CN, KR, JP, SG, IN, HK, TW

The data given are nominal values for the specified application parameters. Jenoptik provides Zemax® BlackBox files for simulating application results for customized parameters (e.g. wavelength, scanner geometry, beam diameter, ...).
Back working distance, Flange focus distance, and focal length vary by ± 1.5 % due to manufacturing variances.

It is our policy to constantly improve the design and specifications. Accordingly, the details represented herein cannot be regarded as final and binding.

F-Theta JENar™ Lens Series

Large Scan Fields – JENar™ 160-1030...1080-170 + VIS

Parameters	JENar™ 160-1030...1080-170 + VIS Compact F-Theta lens for large scan fields
Focal length:	160 mm
Wavelength:	1030...1080 nm; T@500...680 nm > 85 %
Scan field (X x Y); Ø:	(120 mm x 120 mm); 170 mm
Diagonal scan angle:	60°
Back working distance:	178.4 mm
Flange focus distance:	194.1 mm
Input beam Ø 1/e ² :	10 mm
Focus size Ø 1/e ² :	31 µm
a1:	13 mm
a2:	42.5 mm
Telecentricity (only F-Theta with scanner):	17.1° 17.2°
Group delay dispersion (GDD):	934 fs ²
LIDT coating pulsed; CW:	not available yet
LIDT system pulsed; CW:	not available yet
Weight:	0.383 kg
Order Number::	601914

Spot properties

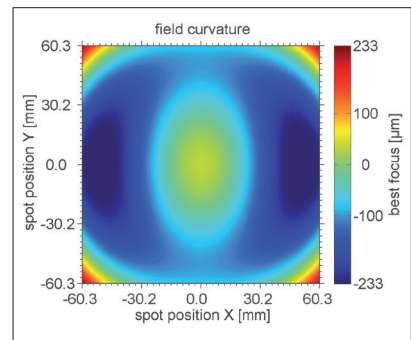
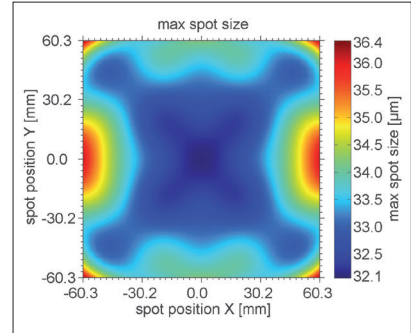

Specifications

JENar™ 160-1030...1080-170 + VIS

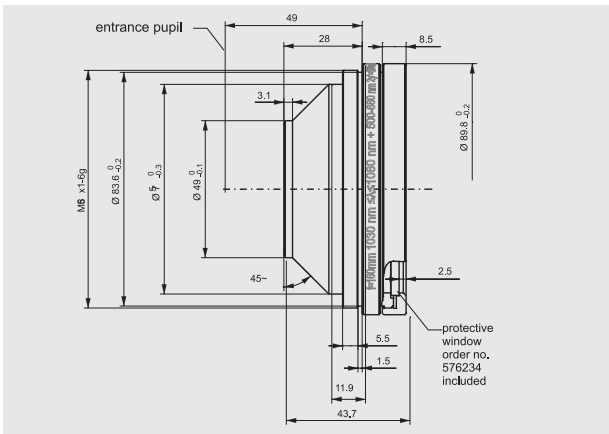

Definition of geometrical parameters

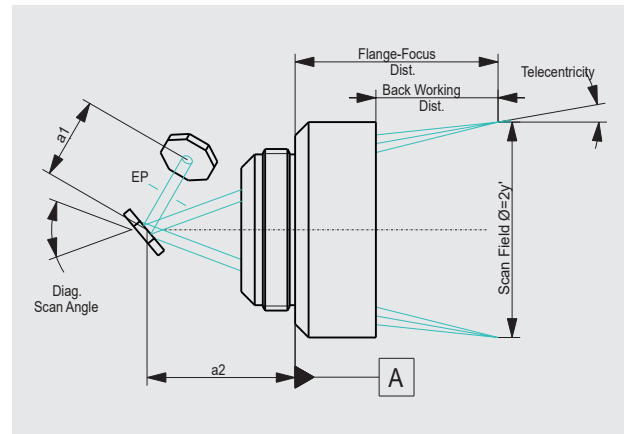

JENar™: Registered in EU, CN, JP, SG, US | F-Theta: Registered Design in EU, CN, KR, JP, SG, IN, HK, TW

The data given are nominal values for the specified application parameters. Jenoptik provides Zemax® BlackBox files for simulating application results for customized parameters (e.g. wavelength, scanner geometry, beam diameter, ...).
Back working distance, Flange focus distance, and focal length vary by ± 1.5 % due to manufacturing variances.

It is our policy to constantly improve the design and specifications. Accordingly, the details represented herein cannot be regarded as final and binding.

F-Theta JENar™ Lens Series

Larger Beam Diameters and Scan Fields – JENar™ 255-1030...1080-239 + VIS

Parameters	JENar™ 255-1030...1080-239 + VIS for larger beam diameters and scan fields
Focal length:	255 mm
Wavelength:	1030...1080 nm; T@500...680 nm > 85 %
Scan field (X x Y); Ø:	(169 mm x 169 mm); 239 mm
Diagonal scan angle:	53.2°
Back working distance:	291 mm
Flange focus distance:	336 mm
Input beam Ø 1/e²:	20 mm
Focus size Ø 1/e²:	24 µm
a1:	25 mm
a2:	39 mm
Telecentricity (only F-Theta with scanner):	14.3° 15°
Group delay dispersion (GDD):	3670 fs²
LIDT coating pulsed; CW:	not available yet
LIDT system pulsed; CW:	not available yet
Weight:	1.4 kg
Order Number::	601948

Spot properties

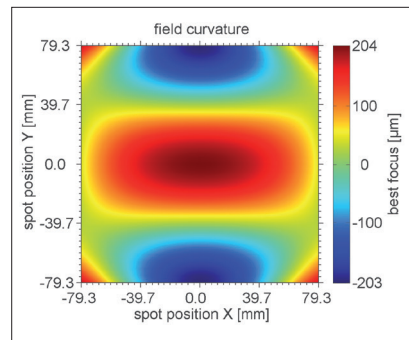
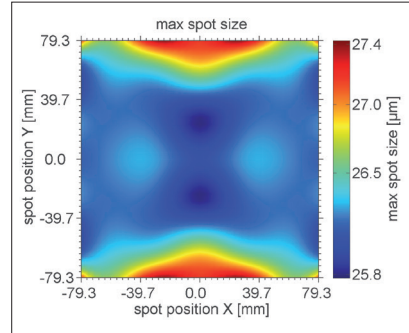

Specifications

JENar™ 255-1030...1080-239 + VIS

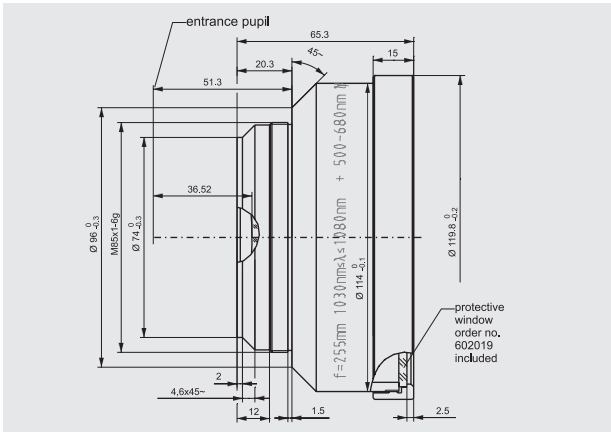

Definition of geometrical parameters

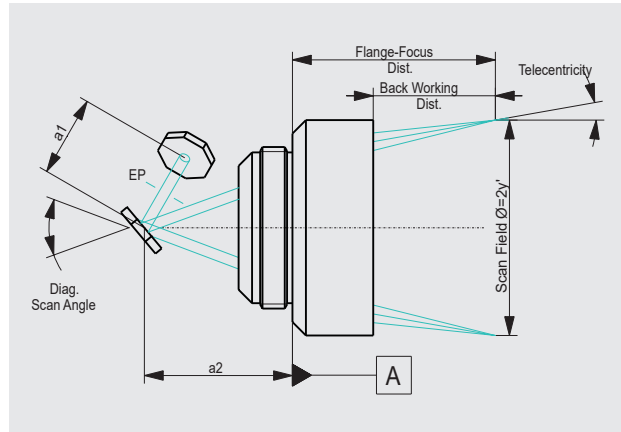

JENar™ Registered in EU, CN, JP, SG, US | F-Theta: Registered Design in EU, CN, KR, JP, SG, IN, HK, TW

The data given are nominal values for the specified application parameters. Jenoptik provides Zemax® BlackBox files for simulating application results for customized parameters (e.g. wavelength, scanner geometry, beam diameter, ...).
Back working distance, Flange focus distance, and focal length vary by ± 1.5 % due to manufacturing variances.

It is our policy to constantly improve the design and specifications. Accordingly, the details represented herein cannot be regarded as final and binding.

F-Theta JENar™ Lens Series

High Image Quality – JENar™ 100-1030...1080-93

Parameters	JENar™ 100-1030...1080-93 F-Theta lens for high image quality
Focal length:	100 mm
Wavelength:	1030...1080 nm
Scan field (X x Y); Ø:	(66 mm x 66 mm); 93 mm
Diagonal scan angle:	54°
Back working distance:	87 mm
Flange focus distance:	136.3 mm
Input beam Ø 1/e²:	10 mm
Focus size Ø 1/e²:	19 µm
a1:	13 mm
a2:	42.5 mm
Telecentricity (only F-Theta with scanner):	8.7° 9.1°
Group delay dispersion (GDD):	1710 fs²
LIDT coating pulsed; CW:	5.0 J/cm² * (τ/[ns]) ^ 0.30; 5.0 MW/cm²
LIDT system pulsed; CW:	5.0 J/cm² * (τ/[ns]) ^ 0.30; 5.0 MW/cm²
Weight:	0.7 kg
Order Number::	017700-024-26

Spot properties

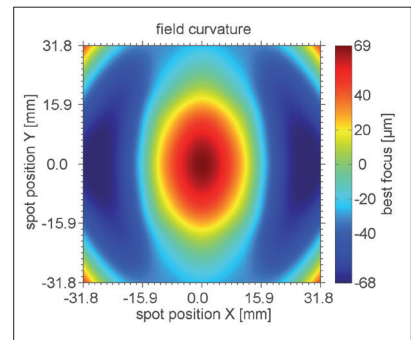
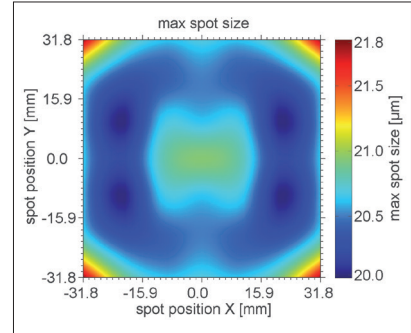

Specifications JENar™ 100-1030...1080-93

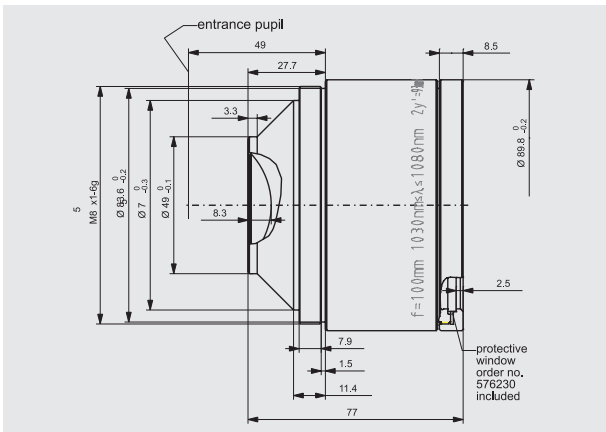

Definition of geometrical parameters

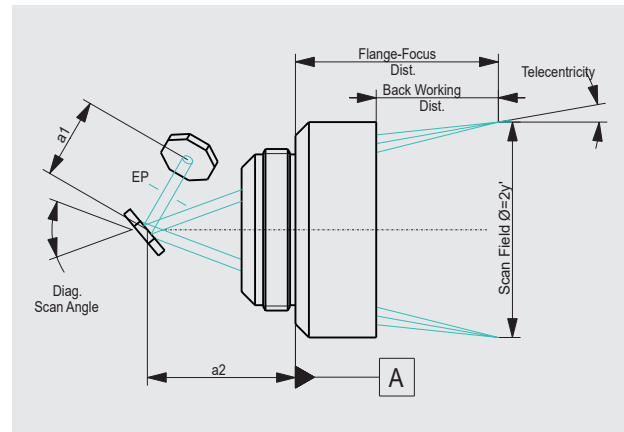

JENar™: Registered in EU, CN, JP, SG, US | F-Theta: Registered Design in EU, CN, KR, JP, SG, IN, HK, TW

The data given are nominal values for the specified application parameters. Jenoptik provides Zemax® BlackBox files for simulating application results for customized parameters (e.g. wavelength, scanner geometry, beam diameter, ...).
Back working distance, Flange focus distance, and focal length vary by ± 1.5 % due to manufacturing variances.

It is our policy to constantly improve the design and specifications. Accordingly, the details represented herein cannot be regarded as final and binding.

F-Theta JENar™ Lens Series

Telecentric Lens – JENar™ 125-1030...1080-80

Parameters	JENar™ 125-1030...1080-80 Telecentric lens
Focal length:	125 mm
Wavelength:	1030...1080 nm
Scan field (X x Y); Ø:	(57 mm x 57 mm); 80 mm
Diagonal scan angle:	± 18.6°
Back working distance:	152.6 mm
Flange focus distance:	196.9 mm
Input beam Ø 1/e ² :	15 mm
Focus size Ø 1/e ² :	16 µm
a1:	18.2 mm
a2:	37.65 mm
Telecentricity (only F-Theta with scanner):	4.9° 5.1°
Group delay dispersion (GDD):	3670 fs ²
LIDT coating pulsed; CW:	5.0 J/cm ² * (τ/[ns]) ^ 0.30; 5.0 MW/cm ²
LIDT system pulsed; CW:	not available yet
Weight:	0.86 kg
Order Number::	017700-003-26

Spot properties

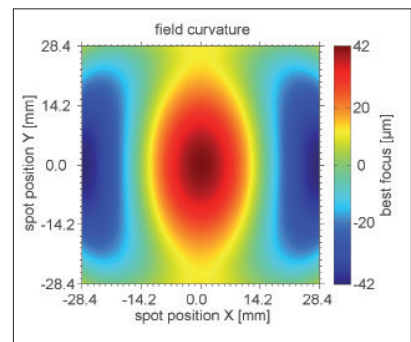
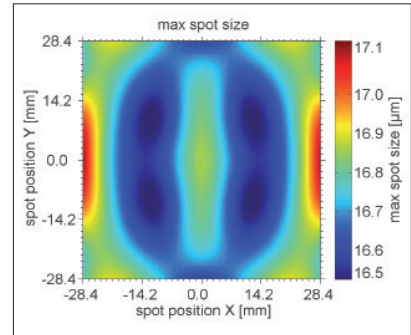

Specifications

JENar™ 125-1030...1080-80

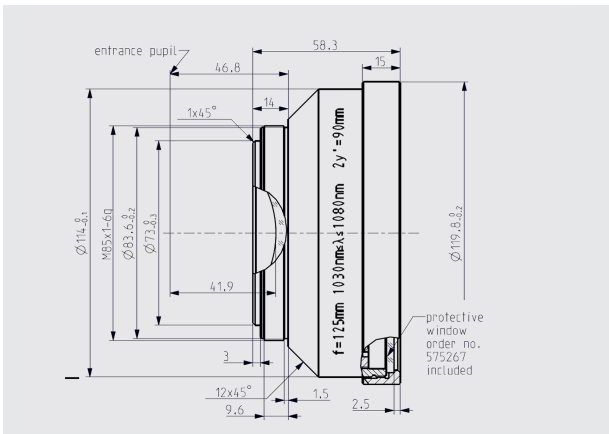

Definition of geometrical parameters

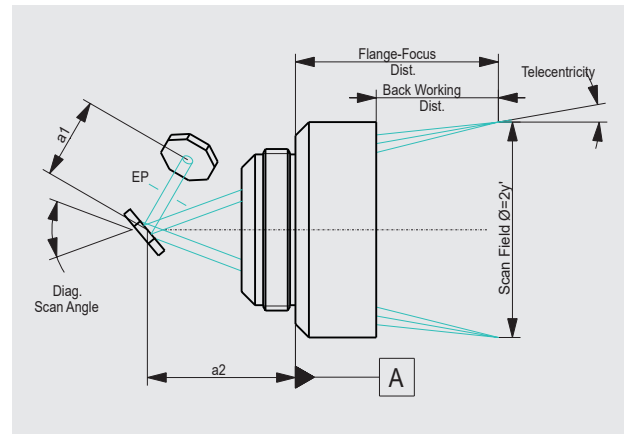

JENar™ Registered in EU, CN, JP, SG, US | F-Theta: Registered Design in EU, CN, KR, JP, SG, IN, HK, TW

The data given are nominal values for the specified application parameters. Jenoptik provides Zemax® BlackBox files for simulating application results for customized parameters (e.g. wavelength, scanner geometry, beam diameter, ...).
Back working distance, Flange focus distance, and focal length vary by ± 1.5 % due to manufacturing variances.

It is our policy to constantly improve the design and specifications. Accordingly, the details represented herein cannot be regarded as final and binding.

F-Theta JENar™ Lens Series

Large Scan Fields – JENar™ 160-1030...1080-170

Parameters	JENar™ 160-1030...1080-170 Compact F-Theta lens for large scan fields
Focal length:	160 mm
Wavelength:	1030...1080 nm
Scan field (X x Y); Ø:	(120 mm x 120 mm); 170 mm
Diagonal scan angle:	60°
Back working distance:	178.4 mm
Flange focus distance:	194.1 mm
Input beam Ø 1/e²:	10 mm
Focus size Ø 1/e²:	31 µm
a1:	13 mm
a2:	42.5 mm
Telecentricity (only F-Theta with scanner):	17.1° 17.2°
Group delay dispersion (GDD):	934 fs²
LIDT coating pulsed; CW:	5.0 J/cm² * (τ/[ns]) ^ 0.30; 5.0 MW/cm²
LIDT system pulsed; CW:	5.0 J/cm² * (τ/[ns]) ^ 0.30; 5.0 MW/cm²
Weight:	0.383 kg
Order Number::	017700-019-26

Spot properties

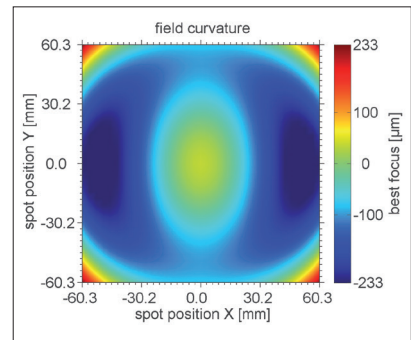
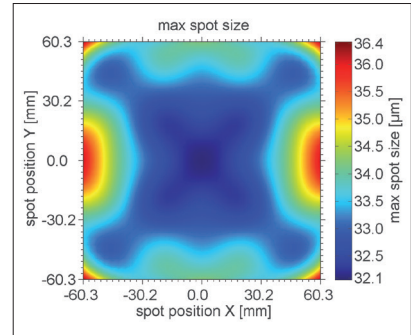

Specifications

JENar™ 160-1030...1080-170

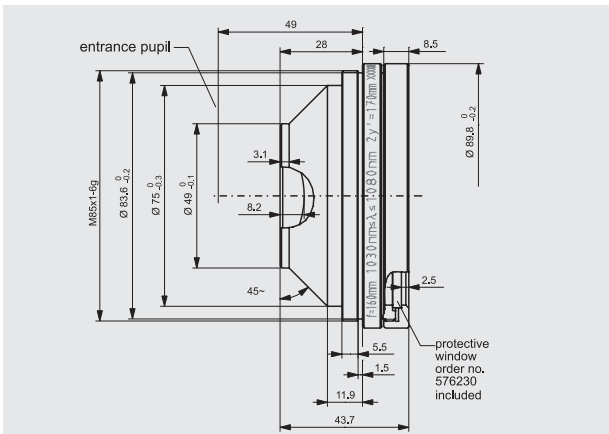

Definition of geometrical parameters

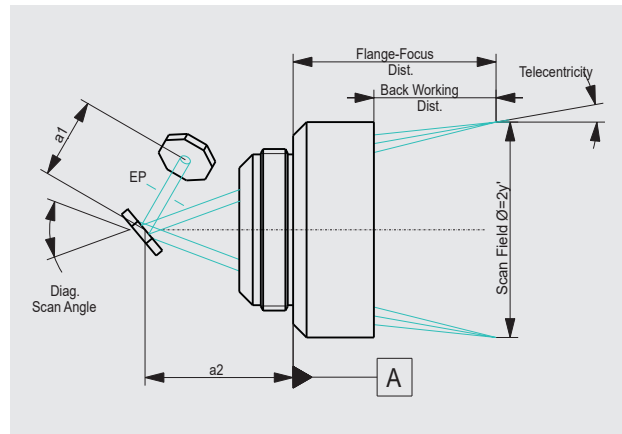

JENar™: Registered in EU, CN, JP, SG, US | F-Theta: Registered Design in EU, CN, KR, JP, SG, IN, HK, TW

The data given are nominal values for the specified application parameters. Jenoptik provides Zemax® BlackBox files for simulating application results for customized parameters (e.g. wavelength, scanner geometry, beam diameter, ...).
Back working distance, Flange focus distance, and focal length vary by ± 1.5 % due to manufacturing variances.

It is our policy to constantly improve the design and specifications. Accordingly, the details represented herein cannot be regarded as final and binding.

F-Theta JENar™ Lens Series

High Image Quality – JENar™ 170-1030...1080-170

Parameters	JENar™ 170-1030...1080-170 F-Theta lens for high image quality
Focal length:	170 mm
Wavelength:	1030...1080 nm
Scan field (X x Y); Ø:	(120 mm x 120 mm); 170 mm
Diagonal scan angle:	57.4°
Back working distance:	194 mm
Flange focus distance:	243.2 mm
Input beam Ø 1/e²:	14 mm
Focus size Ø 1/e²:	24 µm
a1:	17 mm
a2:	40.5 mm
Telecentricity (only F-Theta with scanner):	11.6° 11.7°
Group delay dispersion (GDD):	1870 fs²
LIDT coating pulsed; CW:	5.0 J/cm² * (τ/[ns]) ^ 0.30; 5.0 MW/cm²
LIDT system pulsed; CW:	5.0 J/cm² * (τ/[ns]) ^ 0.30; 5.0 MW/cm²
Weight:	1.232 kg
Order Number::	017700-018-26

Spot properties

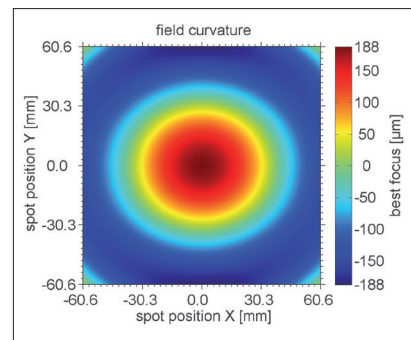
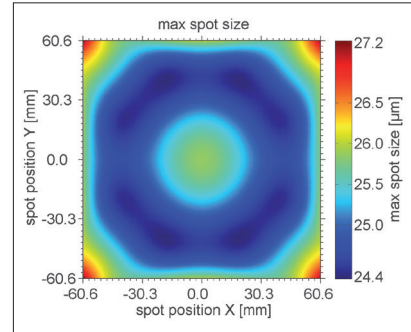

Specifications

JENar™ 170-1030...1080-170

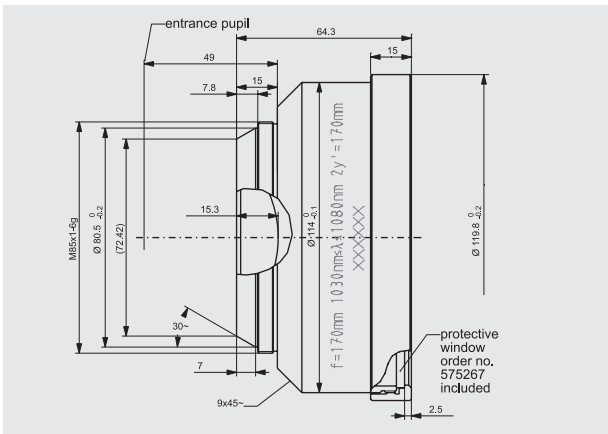

Definition of geometrical parameters

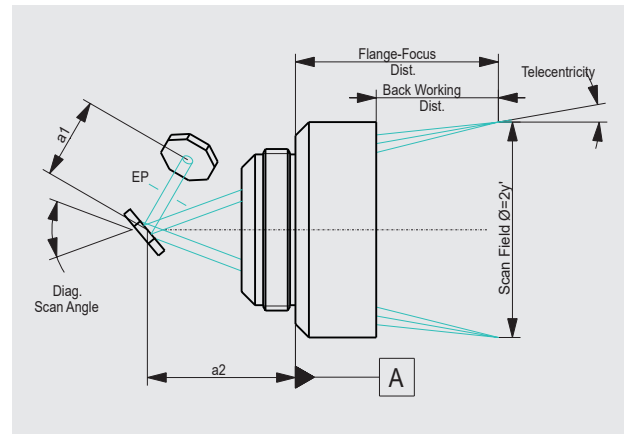

JENar™: Registered in EU, CN, JP, SG, US | F-Theta: Registered Design in EU, CN, KR, JP, SG, IN, HK, TW

The data given are nominal values for the specified application parameters. Jenoptik provides Zemax® BlackBox files for simulating application results for customized parameters (e.g. wavelength, scanner geometry, beam diameter, ...).
Back working distance, Flange focus distance, and focal length vary by ± 1.5 % due to manufacturing variances.

It is our policy to constantly improve the design and specifications. Accordingly, the details represented herein cannot be regarded as final and binding.

F-Theta JENar™ Lens Series

Larger Beam Diameters and Scan Fields – JENar™ 255-1030...1080-239

Parameters	JENar™ 255-1030...1080-239 Lens for larger beam diameters and scan fields
Focal length:	255 mm
Wavelength:	1030...1080 nm
Scan field (X x Y); Ø:	(169 mm x 169 mm); 239 mm
Diagonal scan angle:	53.2°
Back working distance:	291 mm
Flange focus distance:	336 mm
Input beam Ø 1/e²:	20 mm
Focus size Ø 1/e²:	24 µm
a1:	25 mm
a2:	39 mm
Telecentricity (only F-Theta with scanner):	14.3° 15°
Group delay dispersion (GDD):	3670 fs²
LIDT coating pulsed; CW:	5.0 J/cm² * (τ/[ns]) ^ 0.30; 5.0 MW/cm²
LIDT system pulsed; CW:	2.5 J/cm² * (τ/[ns]) ^ 0.30; 2.5 MW/cm²
Weight:	1.4 kg
Order Number::	017700-017-26

Spot properties

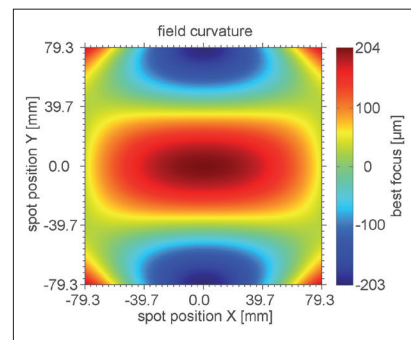
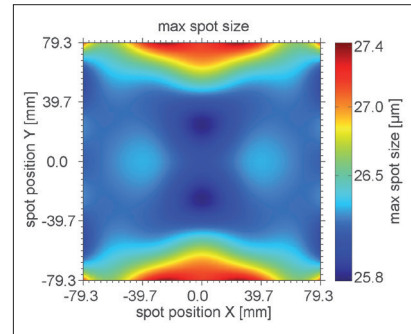

Specifications

JENar™ 255-1030...1080-239

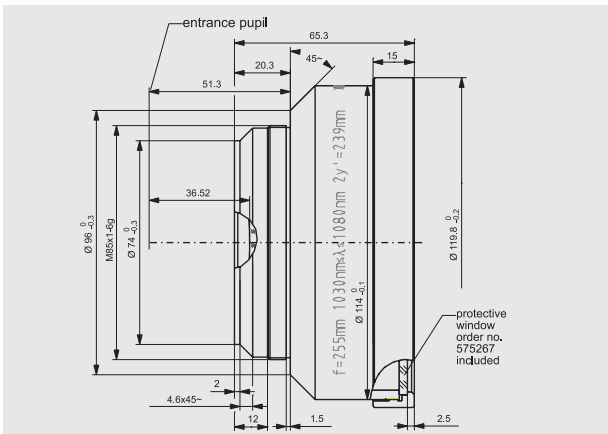

Definition of geometrical parameters

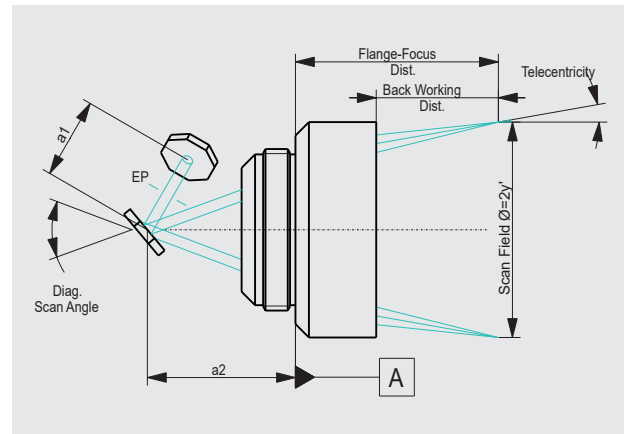

JENar™: Registered in EU, CN, JP, SG, US | F-Theta: Registered Design in EU, CN, KR, JP, SG, IN, HK, TW

The data given are nominal values for the specified application parameters. Jenoptik provides Zemax® BlackBox files for simulating application results for customized parameters (e.g. wavelength, scanner geometry, beam diameter, ...).
Back working distance, Flange focus distance, and focal length vary by ± 1.5 % due to manufacturing variances.

It is our policy to constantly improve the design and specifications. Accordingly, the details represented herein cannot be regarded as final and binding.

F-Theta JENar™ Lens Series

Large Scan Fields – JENar™ 347-1030...1080-355

Parameters	JENar™ 347-1030...1080-355 Lens for large scan fields & reflex optimized
Focal length:	347 mm
Wavelength:	1030...1080 nm
Scan field (X x Y); Ø:	(254 mm x 254 mm); 355 mm
Diagonal scan angle:	± 29.1°
X/Y mirror angle:	± 10.4°
Back working distance:	403.6 mm
Flange focus distance:	441 mm
Input beam Ø 1/e ² :	15 mm
Focus size Ø 1/e ² :	46 µm
a1 a2:	17 mm 40.5 mm
Telecentricity (only F-Theta with scanner):	18.2° 18.2°
Group delay dispersion (GDD):	1880 fs ²
LIDT coating pulsed; CW:	5.0 J/cm ² * (τ/[ns]) ^ 0.30; 5.0 MW/cm ²
LIDT system pulsed; CW:	5.0 J/cm ² * (τ/[ns]) ^ 0.30; 5.0 MW/cm ²
Weight:	0.8 kg
Order Number:	609661

Spot properties

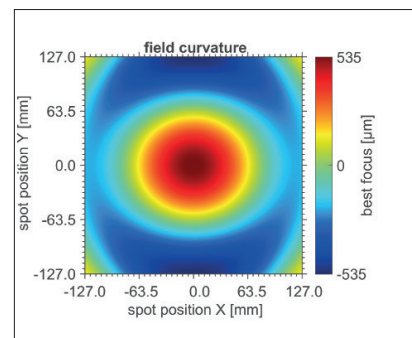
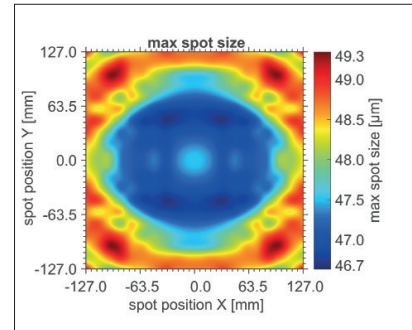

Specifications

JENar™ 347-1030...1080-355

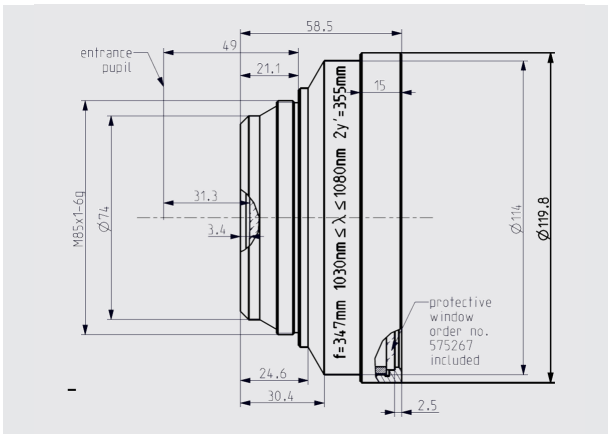

Definition of geometrical parameters

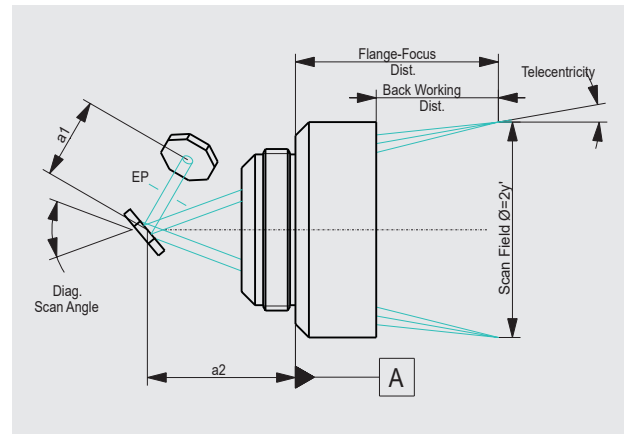

JENar™: Registered in EU, CN, JP, SG, US | F-Theta: Registered Design in EU, CN, KR, JP, SG, IN, HK, TW

The data given are nominal values for the specified application parameters. Jenoptik provides Zemax® BlackBox files for simulating application results for customized parameters (e.g. wavelength, scanner geometry, beam diameter, ...).
Back working distance, Flange focus distance, and focal length vary by ± 1.5 % due to manufacturing variances.

It is our policy to constantly improve the design and specifications. Accordingly, the details represented herein cannot be regarded as final and binding.

F-Theta JENar™ Lens Series

Large Scan Fields – JENar™ 347-1030...1080-354

Parameters	JENar™ 347-1030...1080-354 F-Theta lens for large scan fields
Focal length:	347 mm
Wavelength:	1030...1080 nm
Scan field (X x Y); Ø:	(250 mm x 250 mm); 354 mm
Diagonal scan angle:	57.6°
Back working distance:	403.8 mm
Flange focus distance:	445.8 mm
Input beam Ø 1/e²:	16 mm
Focus size Ø 1/e²:	46 µm
a1:	17 mm
a2:	40.5 mm
Telecentricity (only F-Theta with scanner):	18.7° 18.7°
Group delay dispersion (GDD):	2140 fs²
LIDT coating pulsed; CW:	5.0 J/cm² * (τ/[ns]) ^ 0.30; 5.0 MW/cm²
LIDT system pulsed; CW:	5.0 J/cm² * (τ/[ns]) ^ 0.30; 5.0 MW/cm²
Weight:	1.3 kg
Order Number::	017700-022-26

Spot properties

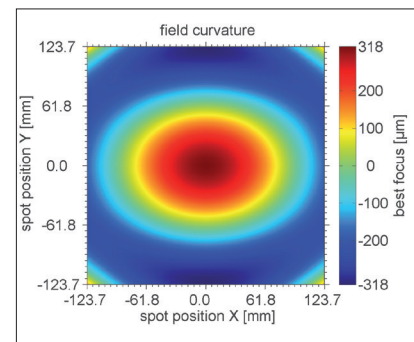
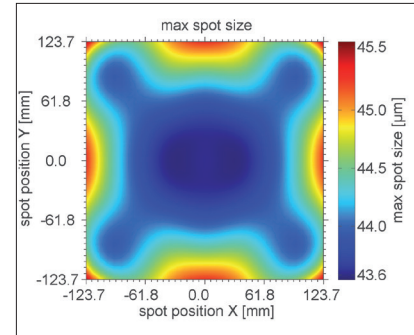

Specifications

JENar™ 347-1030...1080-354

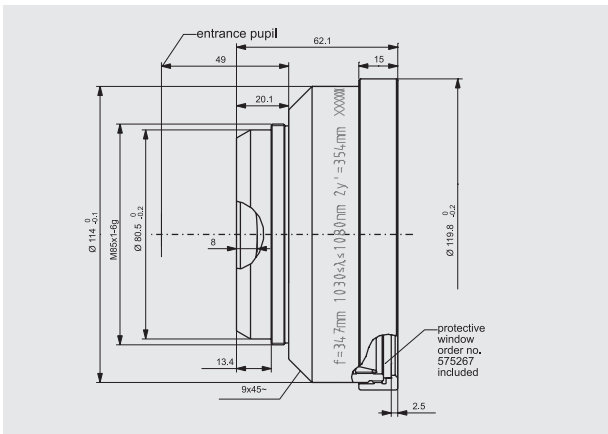

Definition of geometrical parameters

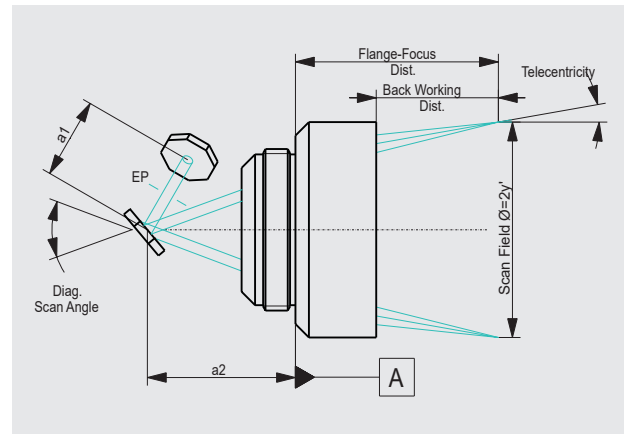

JENar™: Registered in EU, CN, JP, SG, US | F-Theta: Registered Design in EU, CN, KR, JP, SG, IN, HK, TW

The data given are nominal values for the specified application parameters. Jenoptik provides Zemax® BlackBox files for simulating application results for customized parameters (e.g. wavelength, scanner geometry, beam diameter, ...).
Back working distance, Flange focus distance, and focal length vary by ± 1.5 % due to manufacturing variances.

It is our policy to constantly improve the design and specifications. Accordingly, the details represented herein cannot be regarded as final and binding.

F-Theta JENar™ Lens Series

Large Scan Fields – JENar™ 350-1030...1080-452

Parameters	JENar™ 350-1030...1080-452 F-Theta lens for large scan fields
Focal length:	350 mm
Wavelength:	1030...1080 nm
Scan field (X x Y); Ø:	(320 mm x 320 mm); 452 mm
Diagonal scan angle:	71°
Back working distance:	395.4 mm
Flange focus distance:	434.5 mm
Input beam Ø 1/e²:	15 mm
Focus size Ø 1/e²:	46 µm
a1:	23.2 mm
a2:	25 mm
Telecentricity (only F-Theta with scanner):	23.7° 24°
Group delay dispersion (GDD):	2850 fs²
LIDT coating pulsed; CW:	5.0 J/cm² * (τ/[ns]) ^ 0.30; 5.0 MW/cm²
LIDT system pulsed; CW:	5.0 J/cm² * (τ/[ns]) ^ 0.30; 5.0 MW/cm²
Weight:	1.14 kg
Order Number::	017700-009-26

Spot properties

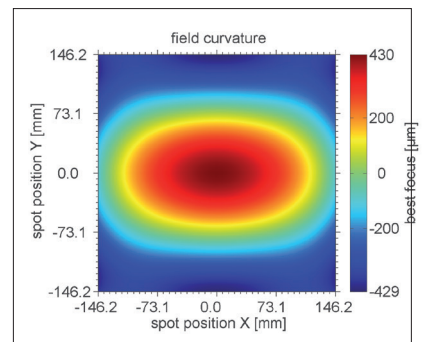
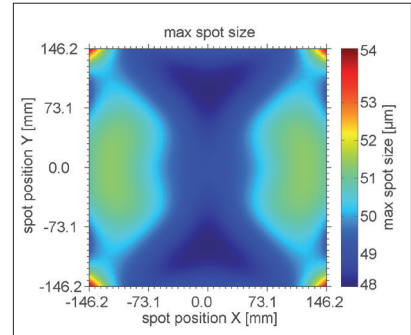

Specifications

JENar™ 350-1030...1080-452

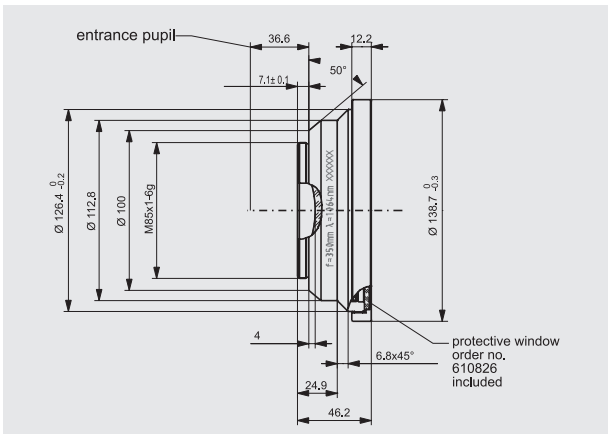

Definition of geometrical parameters

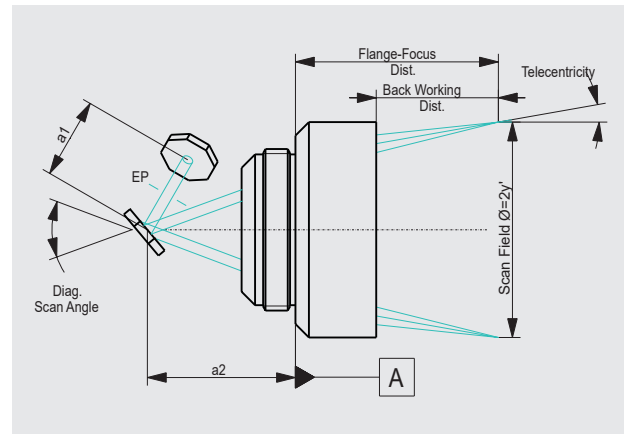

JENar™: Registered in EU, CN, JP, SG, US | F-Theta: Registered Design in EU, CN, KR, JP, SG, IN, HK, TW

The data given are nominal values for the specified application parameters. Jenoptik provides Zemax® BlackBox files for simulating application results for customized parameters (e.g. wavelength, scanner geometry, beam diameter, ...).
Back working distance, Flange focus distance, and focal length vary by ± 1.5 % due to manufacturing variances.

It is our policy to constantly improve the design and specifications. Accordingly, the details represented herein cannot be regarded as final and binding.

F-Theta JENar™ Lens Series

Large Scan Fields – JENar™ 420-1030...1080-420

Parameters	JENar™ 420-1030...1080-420 F-Theta lens for large scan fields
Focal length:	420 mm
Wavelength:	1030...1080 nm
Scan field (X x Y); Ø:	(297 mm x 297 mm); 420 mm
Diagonal scan angle:	57.1°
Back working distance:	500.6 mm
Flange focus distance:	536.3 mm
Input beam Ø 1/e²:	15 mm
Focus size Ø 1/e²:	55 µm
a1:	17 mm
a2:	40.5 mm
Telecentricity (only F-Theta with scanner):	18.7° 18.8°
Group delay dispersion (GDD):	1020 fs²
LIDT coating pulsed; CW:	5.0 J/cm² * (τ/[ns]) ^ 0.30; 5.0 MW/cm²
LIDT system pulsed; CW:	5.0 J/cm² * (τ/[ns]) ^ 0.30; 5.0 MW/cm²
Weight:	0.841 kg
Order Number::	017700-021-26

Spot properties

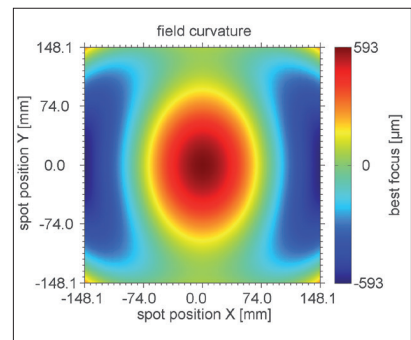
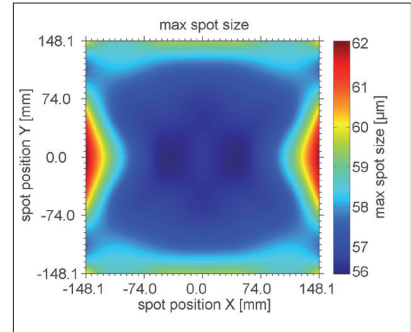

Specifications JENar™ 420-1030...1080-420

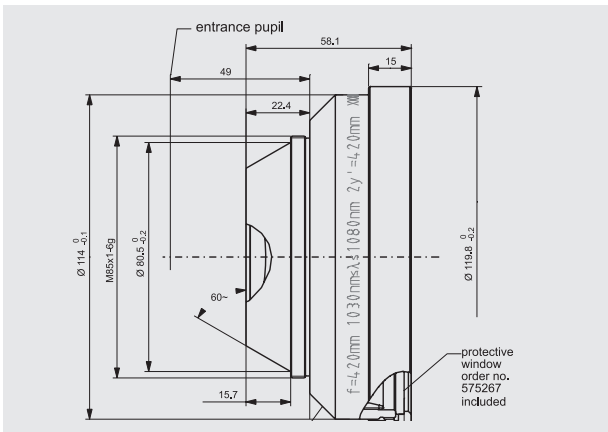

Definition of geometrical parameters

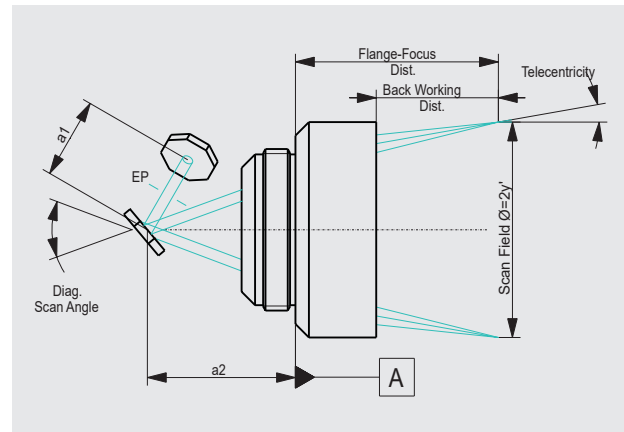

JENar™: Registered in EU, CN, JP, SG, US | F-Theta: Registered Design in EU, CN, KR, JP, SG, IN, HK, TW

The data given are nominal values for the specified application parameters. Jenoptik provides Zemax® BlackBox files for simulating application results for customized parameters (e.g. wavelength, scanner geometry, beam diameter, ...).
Back working distance, Flange focus distance, and focal length vary by ± 1.5 % due to manufacturing variances.

It is our policy to constantly improve the design and specifications. Accordingly, the details represented herein cannot be regarded as final and binding.

F-Theta JENar™ Lens Series

High Image Quality – JENar™ 100-515...540-90

Parameters	JENar™ 100-515...540-90 F-Theta lens for high image quality
Focal length:	100 mm
Wavelength:	515...540 nm
Scan field (X x Y); Ø:	(64 mm x 64 mm); 90 mm
Diagonal scan angle:	53°
Back working distance:	95 mm
Flange focus distance:	140 mm
Input beam Ø 1/e²:	10 mm
Focus size Ø 1/e²:	10 µm
a1:	13 mm
a2:	42.5 mm
Telecentricity (only F-Theta with scanner):	7.7° 7.8°
Group delay dispersion (GDD):	4940 fs²
LIDT coating pulsed; CW:	2.5 J/cm² * (τ/[ns]) ^ 0.35; 2.5 MW/cm²
LIDT system pulsed; CW:	The system LIDT depends strongly on used laser parameters. Please be advised to test.
Weight:	0.7 kg
Order Number::	017700-209-26

Spot properties

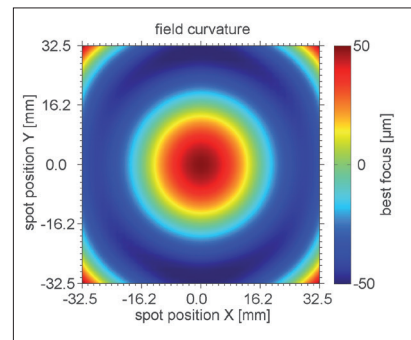
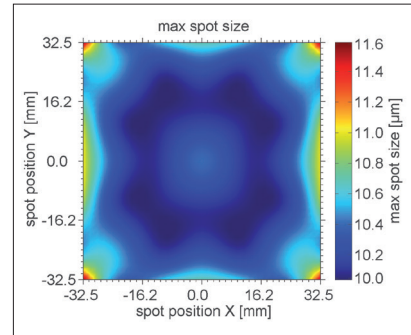

Specifications JENar™ 100-515...540-90

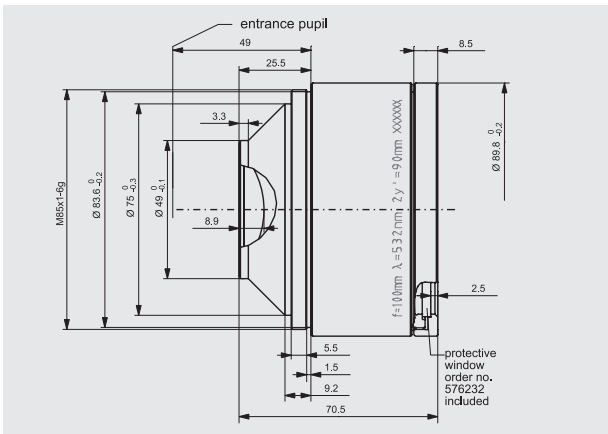

Definition of geometrical parameters

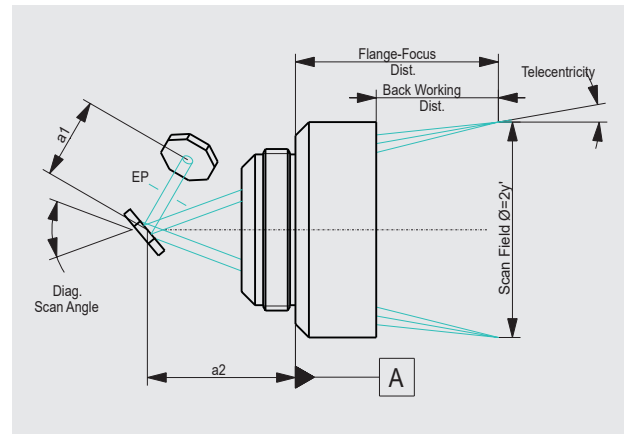

JENar™: Registered in EU, CN, JP, SG, US | F-Theta: Registered Design in EU, CN, KR, JP, SG, IN, HK, TW

The data given are nominal values for the specified application parameters. Jenoptik provides Zemax® BlackBox files for simulating application results for customized parameters (e.g. wavelength, scanner geometry, beam diameter, ...).
Back working distance, Flange focus distance, and focal length vary by ± 1.5 % due to manufacturing variances.

It is our policy to constantly improve the design and specifications. Accordingly, the details represented herein cannot be regarded as final and binding.

F-Theta JENar™ Lens Series

Telecentric Lens – JENar™ 102-515...540-75

Parameters	JENar™ 102-515...540-75 Telecentric lens
Focal length:	102 mm
Wavelength:	515...540 nm
Scan field (X x Y); Ø:	(53 mm x 53 mm); 75 mm
Diagonal scan angle:	43°
Back working distance:	132.9 mm
Flange focus distance:	173.6 mm
Input beam Ø 1/e²:	15 mm
Focus size Ø 1/e²:	7 µm
a1:	18 mm
a2:	36 mm
Telecentricity (only F-Theta with scanner):	4.1° 4.9°
Group delay dispersion (GDD):	15700 fs²
LIDT coating pulsed; CW:	2.5 J/cm² * (τ/[ns]) ^ 0.35; 2.5 MW/cm²
LIDT system pulsed; CW:	The system LIDT depends strongly on used laser parameters. Please be advised to test.
Weight:	0.7 kg
Order Number::	017700-202-26

Spot properties

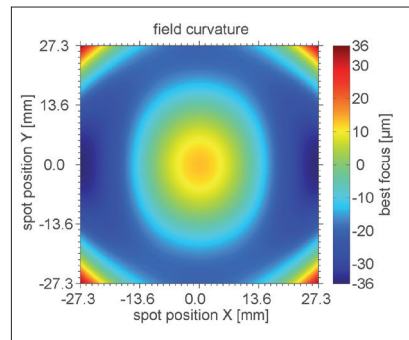
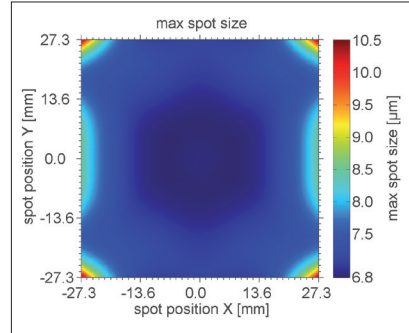

Specifications

JENar™ 102-515...540-75

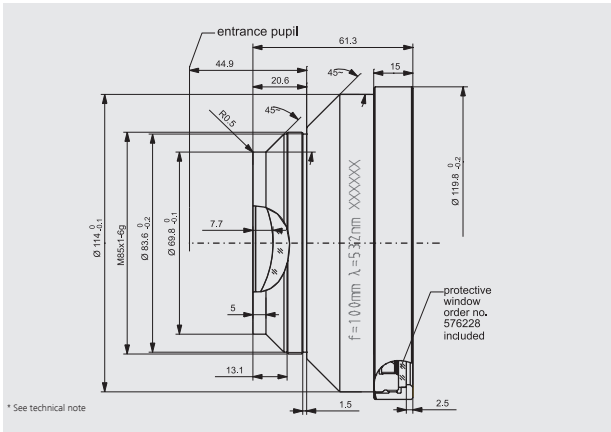

Definition of geometrical parameters

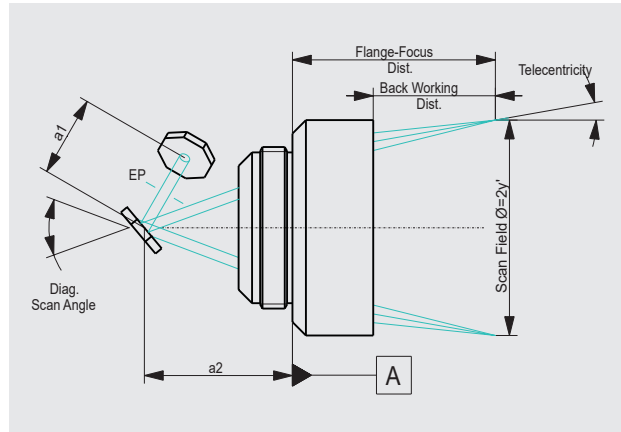

JENar™: Registered in EU, CN, JP, SG, US | F-Theta: Registered Design in EU, CN, KR, JP, SG, IN, HK, TW

The data given are nominal values for the specified application parameters. Jenoptik provides Zemax® BlackBox files for simulating application results for customized parameters (e.g. wavelength, scanner geometry, beam diameter, ...).
Back working distance, Flange focus distance, and focal length vary by ± 1.5 % due to manufacturing variances.

It is our policy to constantly improve the design and specifications. Accordingly, the details represented herein cannot be regarded as final and binding.

F-Theta JENar™ Lens Series

Telecentric Lenses – JENar™ 108-515...540-75

Parameters	JENar™ 108-515...540-75 Telecentric lens
Focal length:	108 mm
Wavelength:	515...540 nm
Scan field (X x Y); Ø:	(53 mm x 53 mm); 75 mm
Diagonal scan angle:	40°
Back working distance:	130.2 mm
Flange focus distance:	168.9 mm
Input beam Ø 1/e²:	15 mm
Focus size Ø 1/e²:	7 µm
a1:	16 mm
a2:	39.2 mm
Telecentricity (only F-Theta with scanner):	4.8° 5.6°
Group delay dispersion (GDD)*:	14700 fs²
LIDT coating pulsed; CW*:	2.5 J/cm² * (τ/[ns]) ^ 0.35; 2.5 MW/cm²
LIDT system pulsed; CW*:	The system LIDT depends strongly on used laser parameters. Please be advised to test.
Weight:	0.9 kg
Order Number::	017700-203-26

Spot properties

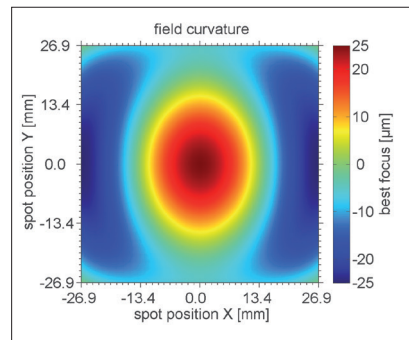
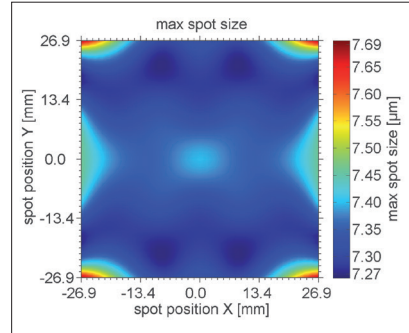

Specifications JENar™ 108-515...540-75

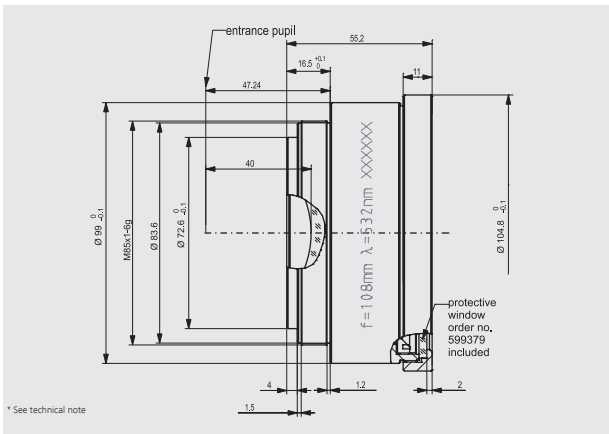

Definition of geometrical parameters

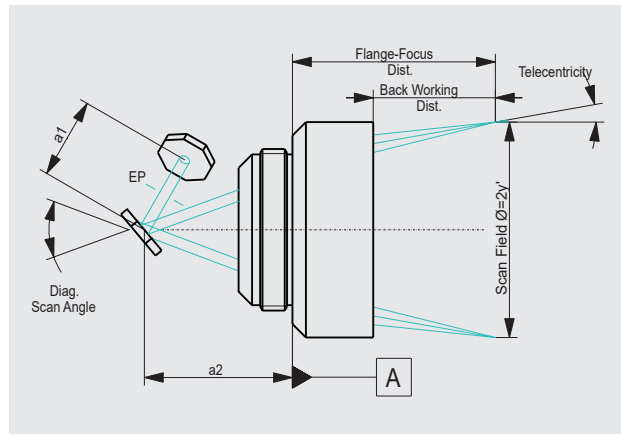

JENar®: Registered in EU, CN, JP, SG, US | F-Theta: Registered Design in EU, CN, KR, JP, SG, IN, HK, TW

The data given are nominal values for the specified application parameters. Jenoptik provides Zemax® BlackBox files for simulating application results for customized parameters (e.g. wavelength, scanner geometry, beam diameter, ...).
Back working distance, Flange focus distance, and focal length vary by ± 1.5 % due to manufacturing variances.

It is our policy to constantly improve the design and specifications. Accordingly, the details represented herein cannot be regarded as final and binding.

F-Theta JENar™ Lens Series

High Image Quality – JENar™ 170-515...540-160

Parameters	JENar™ 170-515...540-160 F-Theta lens for high image quality
Focal length:	170 mm
Wavelength:	515...540 nm
Scan field (X x Y); Ø:	(113 mm x 113 mm); 160 mm
Diagonal scan angle:	54°
Back working distance:	195 mm
Flange focus distance:	244 mm
Input beam Ø 1/e²:	14 mm
Focus size Ø 1/e²:	12 µm
a1:	17 mm
a2:	40.5 mm
Telecentricity (only F-Theta with scanner):	10.9° 11°
Group delay dispersion (GDD):	7100 fs²
LIDT coating pulsed; CW:	2.5 J/cm² * (τ/[ns]) ^ 0.35; 2.5 MW/cm²
LIDT system pulsed; CW:	The system LIDT depends strongly on used laser parameters. Please be advised to test.
Weight:	1.213 kg
Order Number::	017700-206-26

Spot properties

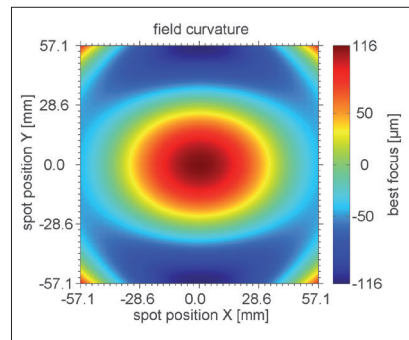
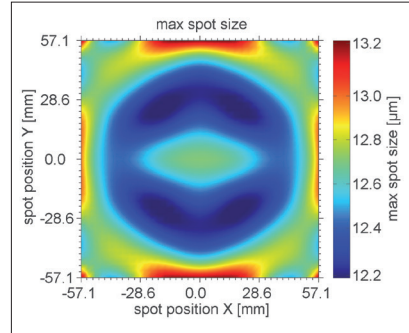

Specifications JENar™ 170-515...540-160

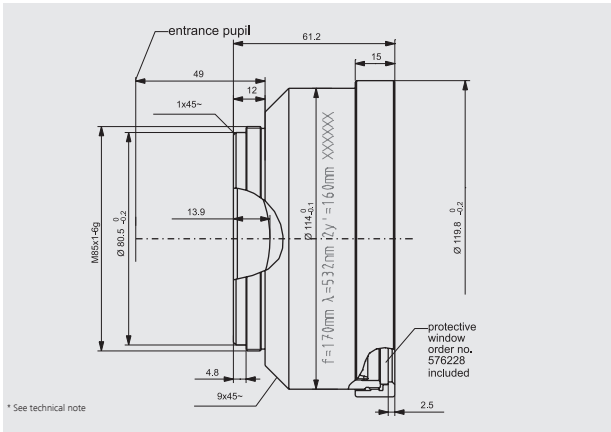

Definition of geometrical parameters

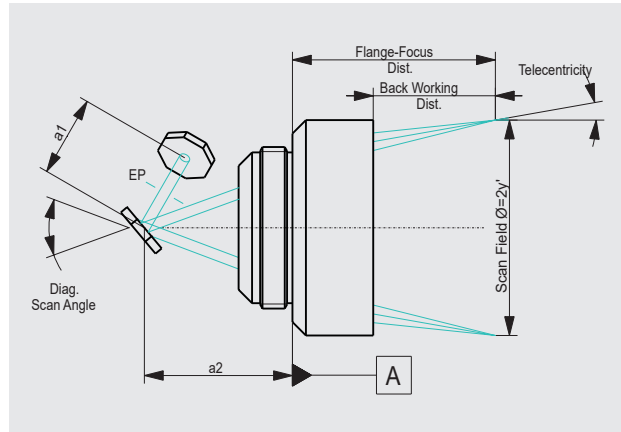

JENar™: Registered in EU, CN, JP, SG, US | F-Theta: Registered Design in EU, CN, KR, JP, SG, IN, HK, TW

The data given are nominal values for the specified application parameters. Jenoptik provides Zemax® BlackBox files for simulating application results for customized parameters (e.g. wavelength, scanner geometry, beam diameter, ...).
Back working distance, Flange focus distance, and focal length vary by ± 1.5 % due to manufacturing variances.

It is our policy to constantly improve the design and specifications. Accordingly, the details represented herein cannot be regarded as final and binding.

F-Theta JENar™ Lens Series

Larger Beam Diameters and Scan Fields – JENar™ 255-515...540-233

Parameters	JENar™ 255-515...540-233 Lens for larger beam diameters and scan fields
Focal length:	255 mm
Wavelength:	515...540 nm
Scan field (X x Y); Ø:	(165 mm x 165 mm); 233 mm
Diagonal scan angle:	52.1°
Back working distance:	294 mm
Flange focus distance:	347 mm
Input beam Ø 1/e ² :	20 mm
Focus size Ø 1/e ² :	12 µm
a1:	25 mm
a2:	39 mm
Telecentricity (only F-Theta with scanner):	14.2° 14.3°
Group delay dispersion (GDD):	7690 fs ²
LIDT coating pulsed; CW:	2.5 J/cm ² * (τ/[ns]) ^ 0.35; 2.5 MW/cm ²
LIDT system pulsed; CW:	The system LIDT depends strongly on used laser parameters. Please be advised to test.
Weight:	1.213 kg
Order Number::	017700-205-26

Spot properties

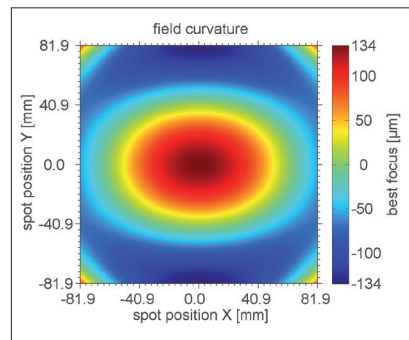
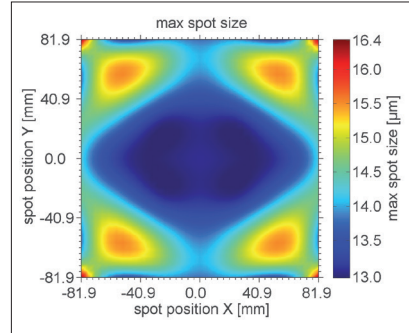

Specifications JENar™ 255-515...540-233

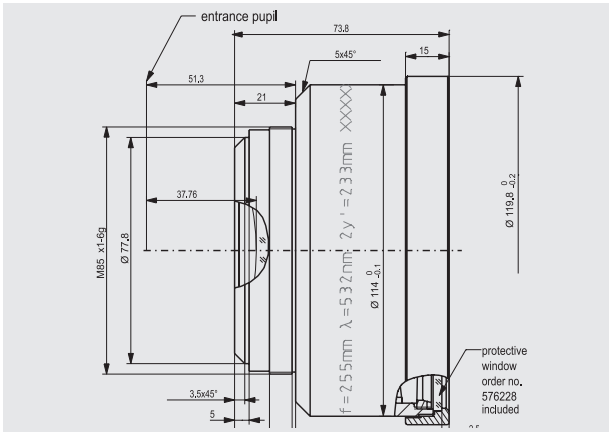

Definition of geometrical parameters

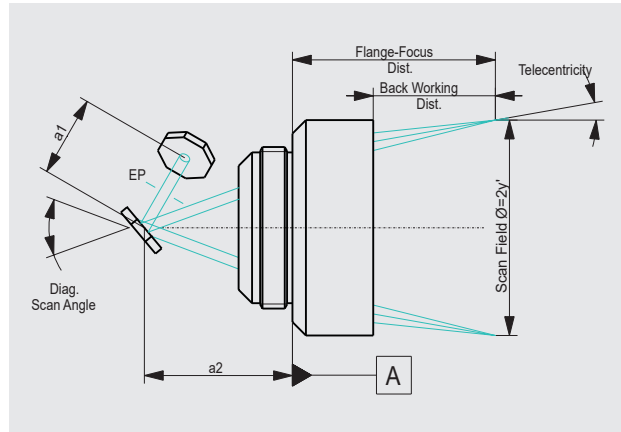

JENar™: Registered in EU, CN, JP, SG, US | F-Theta: Registered Design in EU, CN, KR, JP, SG, IN, HK, TW

The data given are nominal values for the specified application parameters. Jenoptik provides Zemax® BlackBox files for simulating application results for customized parameters (e.g. wavelength, scanner geometry, beam diameter, ...).
Back working distance, Flange focus distance, and focal length vary by ± 1.5 % due to manufacturing variances.

It is our policy to constantly improve the design and specifications. Accordingly, the details represented herein cannot be regarded as final and binding.

F-Theta JENar™ Lens Series

Large Scan Fields – JENar™ 330-515...540-347

Parameters	JENar™ 330-515...540-347 F-Theta lens for large scan fields
Focal length:	330 mm
Wavelength:	515...540 nm
Scan field (X x Y); Ø:	(245 mm x 245 mm); 347 mm
Diagonal scan angle:	57.6°
Back working distance:	384.1 mm
Flange focus distance:	426.1 mm
Input beam Ø 1/e ² :	16 mm
Focus size Ø 1/e ² :	23 µm
a1:	17 mm
a2:	40.5 mm
Telecentricity (only F-Theta with scanner):	18.4° 18.4°
Group delay dispersion (GDD):	6810 fs ²
LIDT coating pulsed; CW:	2.5 J/cm ² * (τ/[ns]) ^ 0.35; 2.5 MW/cm ²
LIDT system pulsed; CW:	The system LIDT depends strongly on used laser parameters. Please be advised to test.
Weight:	1.3 kg
Order Number::	017700-208-26

Spot properties

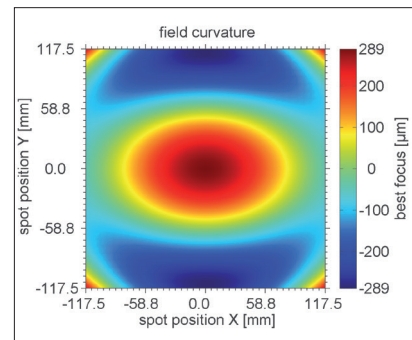
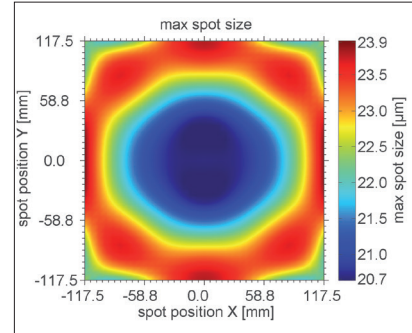

Specifications JENar™ 330-515...540-347

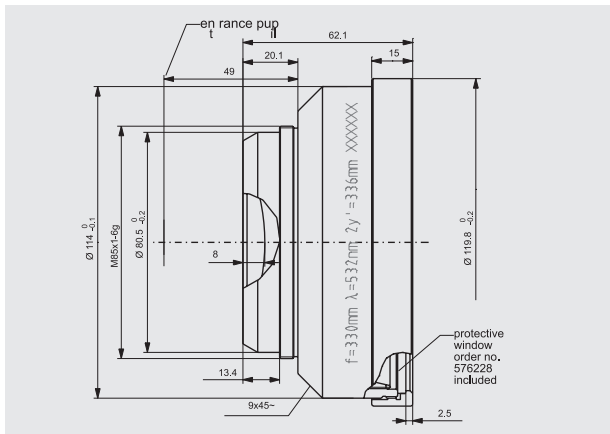

Definition of geometrical parameters

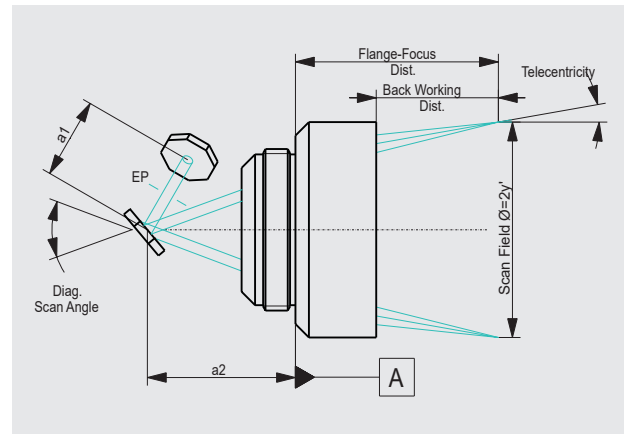

JENar™: Registered in EU, CN, JP, SG, US | F-Theta: Registered Design in EU, CN, KR, JP, SG, IN, HK, TW

The data given are nominal values for the specified application parameters. Jenoptik provides Zemax® BlackBox files for simulating application results for customized parameters (e.g. wavelength, scanner geometry, beam diameter, ...).
Back working distance, Flange focus distance, and focal length vary by ± 1.5 % due to manufacturing variances.

It is our policy to constantly improve the design and specifications. Accordingly, the details represented herein cannot be regarded as final and binding.

F-Theta JENar™ Lens Series

Large Scan Fields – JENar™ 420-515...540-420

Parameters	JENar™ 420-515...540-420 F-Theta lens for large scan fields
Focal length:	420 mm
Wavelength:	515...540 nm
Scan field (X x Y); Ø:	(297 mm x 297 mm); 420 mm
Diagonal scan angle:	57.1°
Back working distance:	485.2 mm
Flange focus distance:	524.3 mm
Input beam Ø 1/e²:	15 mm
Focus size Ø 1/e²:	27 µm
a1:	17 mm
a2:	40.5 mm
Telecentricity (only F-Theta with scanner):	19.3° 19.3°
Group delay dispersion (GDD):	4860 fs²
LIDT coating pulsed; CW:	2.5 J/cm² * (τ/[ns]) ^ 0.35; 2.5 MW/cm²
LIDT system pulsed; CW:	The system LIDT depends strongly on used laser parameters. Please be advised to test.
Weight:	0.978 kg
Order Number::	017700-207-26

Spot properties

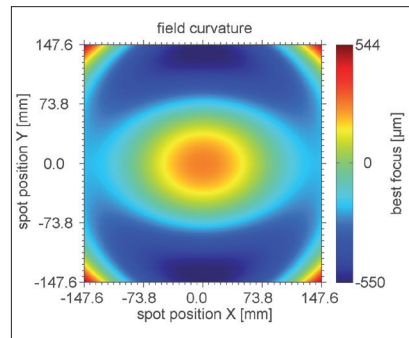
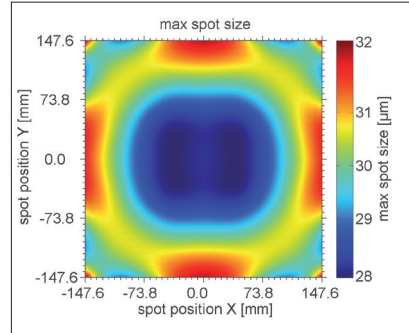

Specifications JENar™ 420-515...540-420

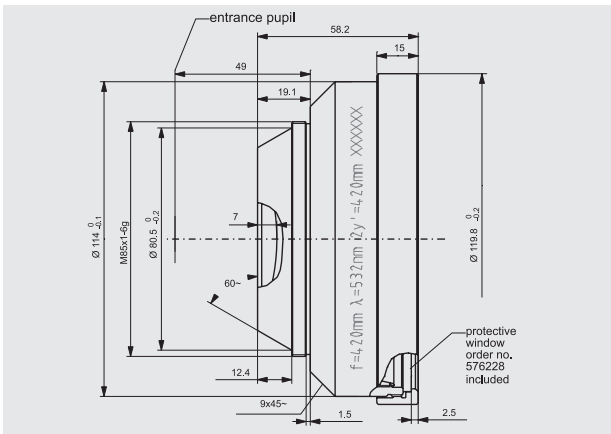

Definition of geometrical parameters

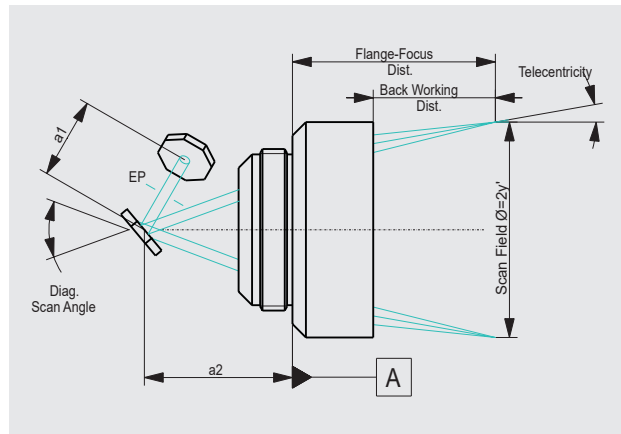

JENar™: Registered in EU, CN, JP, SG, US | F-Theta: Registered Design in EU, CN, KR, JP, SG, IN, HK, TW

The data given are nominal values for the specified application parameters. Jenoptik provides Zemax® BlackBox files for simulating application results for customized parameters (e.g. wavelength, scanner geometry, beam diameter, ...).
Back working distance, Flange focus distance, and focal length vary by ± 1.5 % due to manufacturing variances.

It is our policy to constantly improve the design and specifications. Accordingly, the details represented herein cannot be regarded as final and binding.

F-Theta JENar™ Silverline™ Lens

High Power Lens – JENar™ 160-1030...1080-110

Parameters	JENar™ 160-1030...1080-110 Fused silica lens
Focal length:	160 mm
Wavelength:	1030...1080 nm
Scan field (X x Y); Ø:	(78 mm x 78 mm); 110 mm
Diagonal scan angle:	± 20°
X/Y mirror angle:	± 7.1°
Back working distance:	183.6 mm
Flange focus distance:	267.6 mm
Input beam Ø 1/e ² :	14 mm
Focus size Ø 1/e ² :	22 µm
a1 a2:	17 mm 40.5 mm
Telecentricity (only F-Theta with scanner):	5.2° 5.4°
Absorption:	fused silica: < 15 ppm/cm coating: < 5 ppm (mean = 3 ppm)
Group delay dispersion (GDD):	759 fs ²
LIDT coating pulsed; CW:	5.0 J/cm ² * (τ/[ns]) ^ 0.30; 5.0 MW/cm ²
LIDT system pulsed; CW:	5.0 J/cm ² * (τ/[ns]) ^ 0.30; 5.0 MW/cm ²
Weight:	1.08 kg
Order Number:	017700-025-26

Spot properties

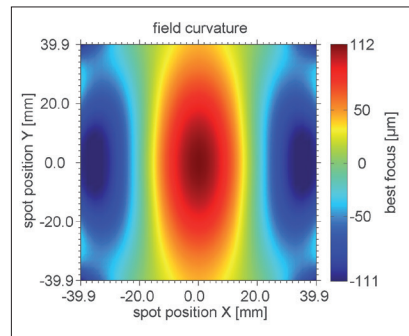
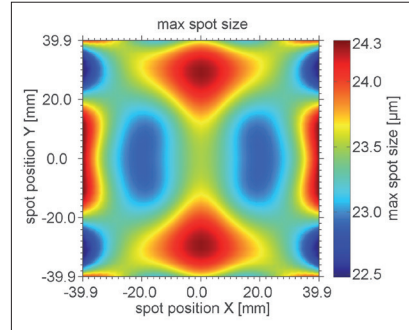

Specifications

JENar™ 160-1030...1080-110

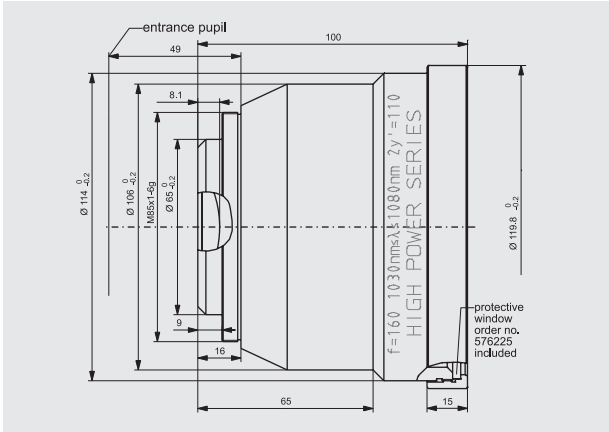

Definition of geometrical parameters

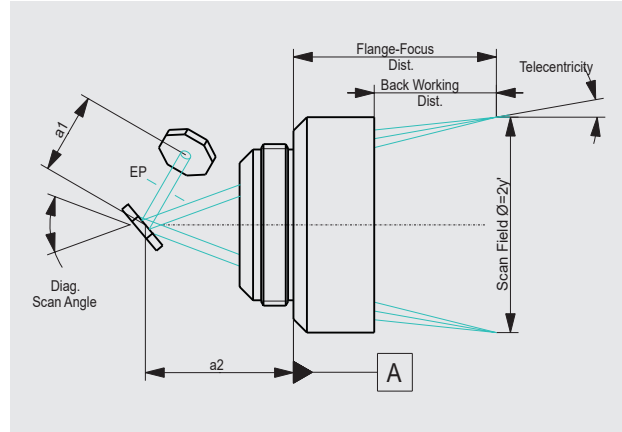

JENar™: Registered in EU, CN, JP, SG, US | Silverline®: Registered in DE, JP, SG, IN

The data given are nominal values for the specified application parameters. Jenoptik provides Zemax® BlackBox files for simulating application results for customized parameters (e.g. wavelength, scanner geometry, beam diameter, ...).
Back working distance, Flange focus distance, and focal length vary by ± 1.5 % due to manufacturing variances.

It is our policy to constantly improve the design and specifications. Accordingly, the details represented herein cannot be regarded as final and binding.

F-Theta JENar™ Silverline™ Lens

High Power Lens – JENar™ 161-1030...1080-71

Parameters	JENar™ 161-1030...1080-71 Fused silica lens for Ultrashort pulse
Focal length:	161 mm
Wavelength:	1030...1080 nm
Scan field (X x Y); Ø:	(50 mm x 50 mm); 71 mm
Diagonal scan angle:	± 12.7°
X/Y mirror angle:	± 4.5°
Back working distance:	153.5 mm
Flange focus distance:	254.5 mm
Input beam Ø 1/e²:	14 mm
Focus size Ø 1/e²:	23 µm
a1 a2:	17 mm 40.5 mm
Telecentricity (only F-Theta with scanner):	4.1° 4.2°
Absorption:	fused silica: < 15 ppm/cm coating: < 5 ppm (mean = 3 ppm)
Group delay dispersion (GDD)	583 fs²
LIDT coating pulsed; CW:	5.0 J/cm² * (τ[ns]) ^ 0.35; 5 MW/cm²
LIDT system pulsed; CW:	5.0 J/cm² * (τ[ns]) ^ 0.35; 5 MW/cm²
Weight:	0.917 kg
Order Number:	660149

Spot properties

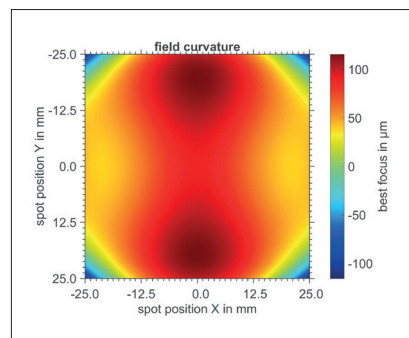
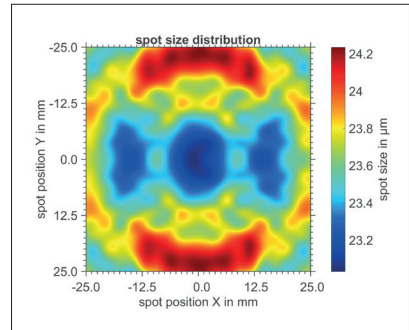

Specifications

JENar™ 161-1030...1080-71

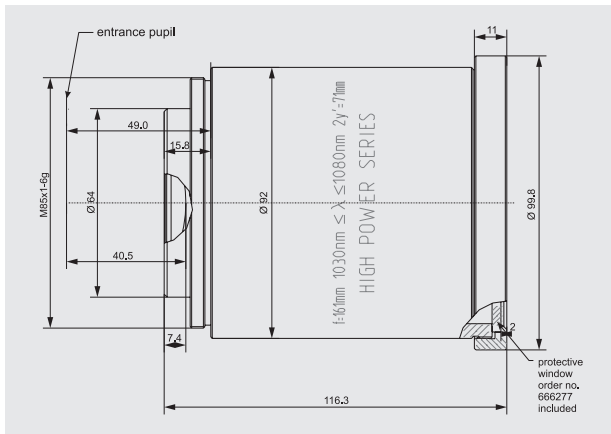

Definition of geometrical parameters

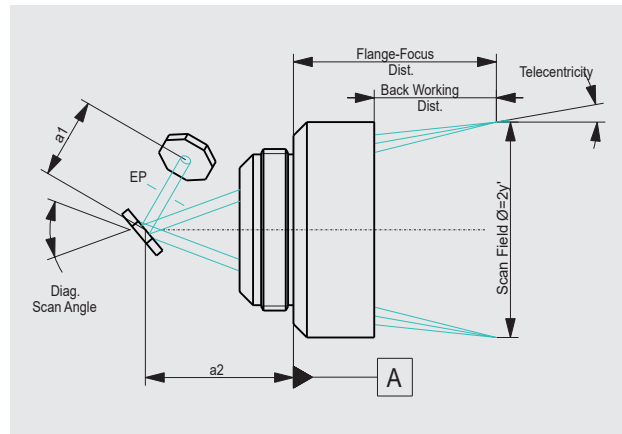

JENar™: Registered in EU, CN, JP, SG, US | Silverline™: Registered in DE, JP, SG, IN

The data given are nominal values for the specified application parameters. Jenoptik provides Zemax® BlackBox files for simulating application results for customized parameters (e.g. wavelength, scanner geometry, beam diameter, ...).
Back working distance, Flange focus distance, and focal length vary by ± 1.5 % due to manufacturing variances.

It is our policy to constantly improve the design and specifications. Accordingly, the details represented herein cannot be regarded as final and binding.

F-Theta JENar™ Silverline™ Lens

High Power Lens – JENar™ 255-1030...1080-160

Parameters	JENar™ 255-1030...1080-160 Fused silica lens
Focal length:	255 mm
Wavelength:	1030...1080 nm
Scan field (X x Y); Ø:	(114 mm x 114 mm); 160 mm
Diagonal scan angle:	± 18°
X/Y mirror angle:	± 6.4°
Back working distance:	303.3 mm
Flange focus distance:	387.8 mm
Input beam Ø 1/e²:	20 mm
Focus size Ø 1/e²:	25 µm
a1 a2:	25 mm 48.46 mm
Telecentricity (only F-Theta with scanner):	7.2° 7.4°
Absorption:	fused silica: < 15 ppm/cm coating: < 5 ppm (mean = 3 ppm)
Group delay dispersion (GDD):	904 fs²
LIDT coating pulsed; CW:	5.0 J/cm² * (τ/[ns]) ^ 0.30; 5.0 MW/cm²
LIDT system pulsed; CW:	5.0 J/cm² * (τ/[ns]) ^ 0.30; 5.0 MW/cm²
Weight:	1.2 kg
Order Number:	017700-026-26

Spot properties

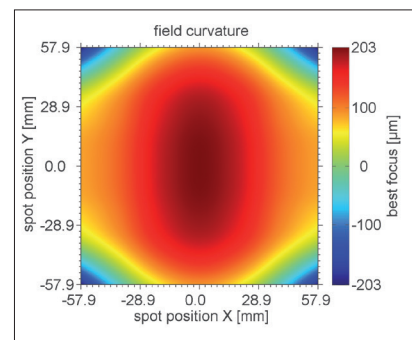
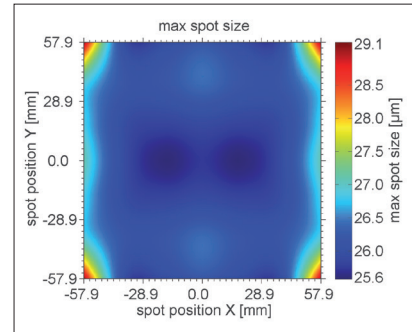

Specifications

JENar™ 255-1030...1080-160

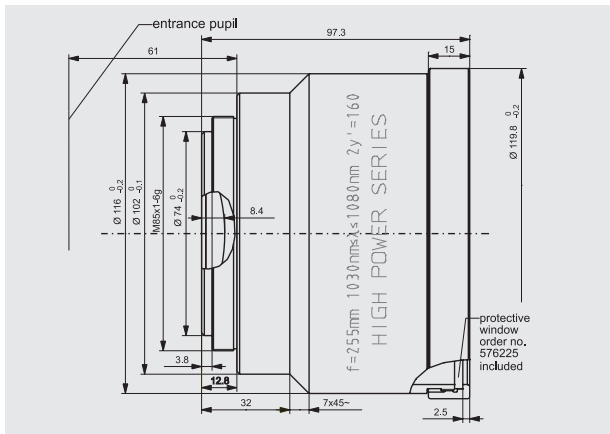

Definition of geometrical parameters

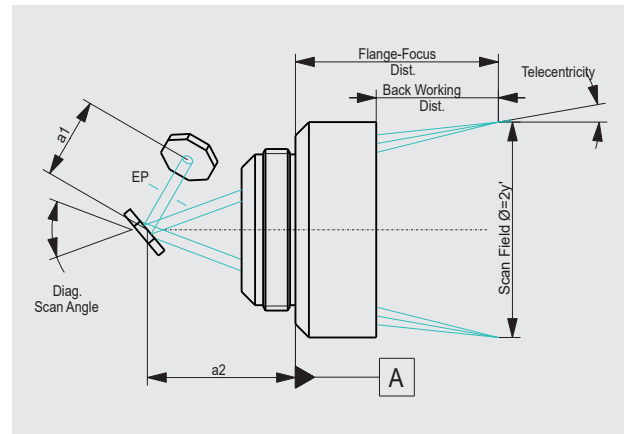

JENar™: Registered in EU, CN, JP, SG, US | Silverline™: Registered in DE, JP, SG, IN

The data given are nominal values for the specified application parameters. Jenoptik provides Zemax® BlackBox files for simulating application results for customized parameters (e.g. wavelength, scanner geometry, beam diameter, ...).
Back working distance, Flange focus distance, and focal length vary by ± 1.5 % due to manufacturing variances.

It is our policy to constantly improve the design and specifications. Accordingly, the details represented herein cannot be regarded as final and binding.

F-Theta JENar™ Silverline™ Lens

High Power Lens – JENar™ 423-1030...1080-360

Parameters	JENar™ 423-1030...1080-360 Fused silica lens for large scan fields**
Focal length:	423 mm
Wavelength:	1030...1080 nm
Scan field (X x Y); Ø:	(255 mm x 255 mm); 360 mm
Diagonal scan angle:	± 24.4°
X/Y mirror angle:	± 8.7°
Back working distance:	500.2 mm
Flange focus distance:	534.1 mm
Input beam Ø 1/e²:	14 mm
Focus size Ø 1/e²:	59 µm
a1 a2:	17 mm 40.5 mm
Telecentricity (only F-Theta with scanner):	16.4° 16.4°
Absorption:	fused silica: < 15 ppm/cm coating: < 5 ppm (mean = 3 ppm)
Group delay dispersion (GDD):	621 fs²
LIDT coating pulsed; CW:	5.0 J/cm² * (τ/[ns]) ^ 0.30; 5.0 MW/cm²
LIDT system pulsed; CW:	5.0 J/cm² * (τ/[ns]) ^ 0.30; 5.0 MW/cm²
Weight:	0.66 kg
Order Number:	609120

Spot properties

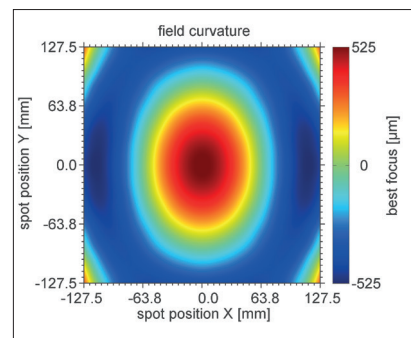
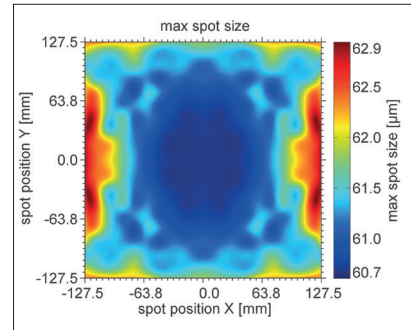

Specifications

JENar™ 423-1030...1080-360

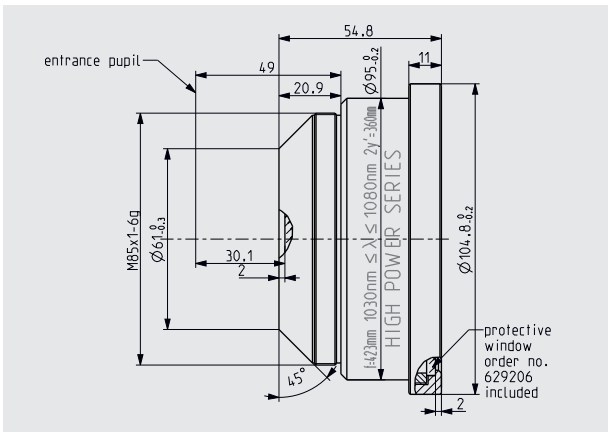

Definition of geometrical parameters

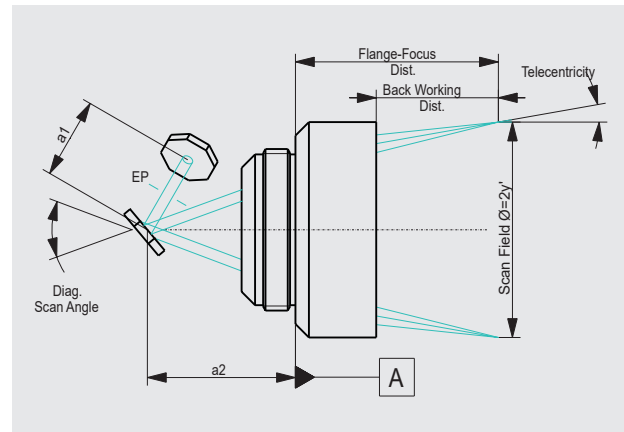

JENar™: Registered in EU, CN, JP, SG, US | Silverline™: Registered in DE, JP, SG, IN

The data given are nominal values for the specified application parameters. Jenoptik provides Zemax® BlackBox files for simulating application results for customized parameters (e.g. wavelength, scanner geometry, beam diameter, ...).
Back working distance, Flange focus distance, and focal length vary by ± 1.5 % due to manufacturing variances.

It is our policy to constantly improve the design and specifications. Accordingly, the details represented herein cannot be regarded as final and binding.

F-Theta JENar™ Silverline™ Lens High Power Lens – JENar™ 160-900...1100-110

Parameters	JENar™ 160-900...1100-110 Fused silica lens
Focal length:	160 mm
Wavelength:	900...1100 nm
Scan field (X x Y); Ø:	(78 mm x 78 mm); 110 mm
Diagonal scan angle:	± 20°
X/Y mirror angle:	± 7.1°
Back working distance:	182.0 mm @ 900 nm; 183.9 mm @ 1100 nm
Flange focus distance:	266.0 mm @ 900 nm; 267.9 mm @ 1100 nm
Input beam Ø 1/e²:	14 mm
Focus size Ø 1/e²:	19 µm @ 900 nm; 23 µm @ 1100 nm
a1 a2:	17 mm 40.5 mm
Telecentricity (only F-Theta with scanner):	5.2° 5.4°
Group delay dispersion (GDD):	759 fs²
LIDT coating pulsed; CW:	not available yet
LIDT system pulsed; CW:	not available yet
Weight:	1.08 kg
Order Number:	601787

Spot properties

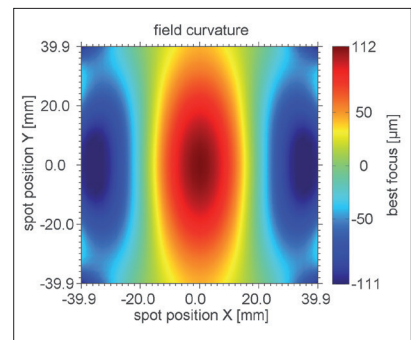
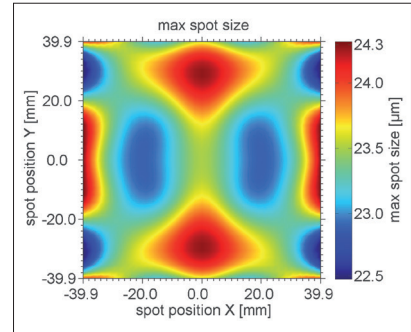

Specifications JENar™ 160-900...1100-110

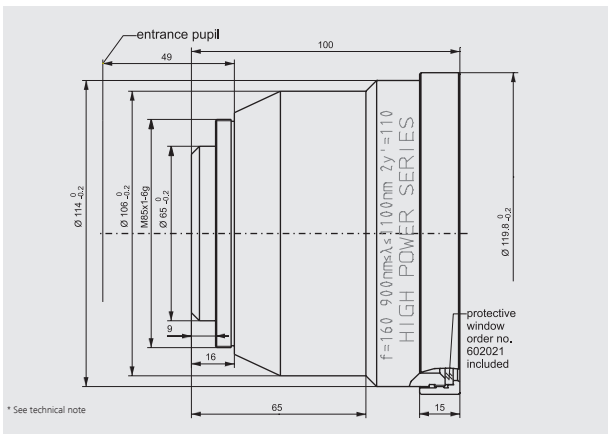

Definition of geometrical parameters

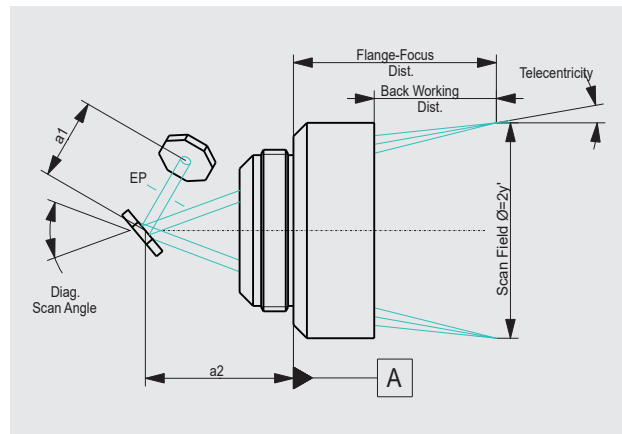

JENar™: Registered in EU, CN, JP, SG, US | Silverline™: Registered in DE, JP, SG, IN

The data given are nominal values for the specified application parameters. Jenoptik provides Zemax® BlackBox files for simulating application results for customized parameters (e.g. wavelength, scanner geometry, beam diameter, ...).
Back working distance, Flange focus distance, and focal length vary by ± 1.5 % due to manufacturing variances.

It is our policy to constantly improve the design and specifications. Accordingly, the details represented herein cannot be regarded as final and binding.

F-Theta JENar™ Silverline™ Lens

High Power Lens – JENar™ 255-900...1100-160

Parameters	JENar™ 255-900...1100-160 Fused silica lens
Focal length:	255 mm
Wavelength:	900...1100 nm
Scan field (X x Y); Ø:	(114 mm x 114 mm); 160 mm
Diagonal scan angle:	± 18°
X/Y mirror angle:	± 6.4°
Back working distance:	301.5 mm @ 900 nm; 304.2 mm @ 1100 nm
Flange focus distance:	386.1 mm @ 900 nm; 388.8 mm @ 1100 nm
Input beam Ø 1/e ² :	20 mm
Focus size Ø 1/e ² :	21 µm @ 900 nm; 26 µm @ 1100 nm
a1 a2:	25 mm 48.46 mm
Telecentricity (only F-Theta with scanner):	7.2° 7.4°
Group delay dispersion (GDD):	904 fs ²
LIDT coating pulsed; CW:	not available yet
LIDT system pulsed; CW:	not available yet
Weight:	1.2 kg
Order Number:	601804

Spot properties

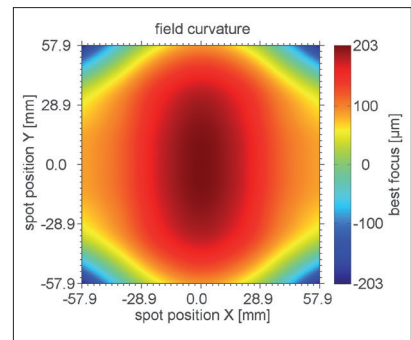
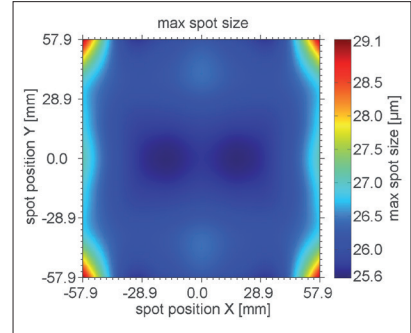

Specifications

JENar™ 255-900...1100-161

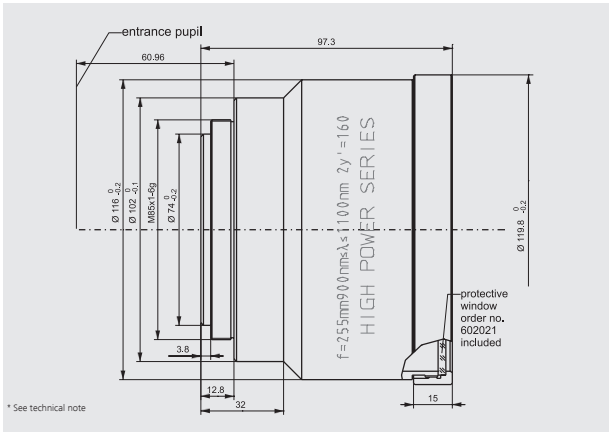

Definition of geometrical parameters

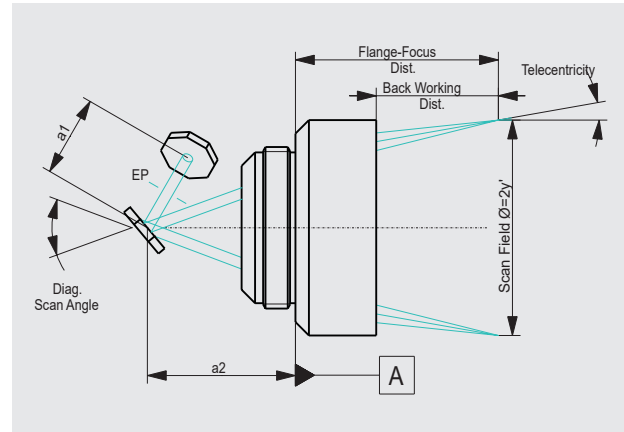

JENar™: Registered in EU, CN, JP, SG, US | Silverline™: Registered in DE, JP, SG, IN

The data given are nominal values for the specified application parameters. Jenoptik provides Zemax® BlackBox files for simulating application results for customized parameters (e.g. wavelength, scanner geometry, beam diameter, ...).
Back working distance, Flange focus distance, and focal length vary by ± 1.5 % due to manufacturing variances.

It is our policy to constantly improve the design and specifications. Accordingly, the details represented herein cannot be regarded as final and binding.

F-Theta JENar™ Silverline™ Lens

High Power Lens – JENar™ 423-900...1100-360

Parameters	JENar™ 423-900...1100-360 Fused silica lens for large scan fields
Focal length:	423 mm
Wavelength:	900...1100 nm
Scan field (X x Y); Ø:	(255 mm x 255 mm); 360 mm
Diagonal scan angle:	± 24.4°
X/Y mirror angle:	± 8.7°
Back working distance:	496.8 mm @ 900 nm; 501.1 mm @ 1100 nm
Flange focus distance:	530.7 mm @ 900 nm; 535.0 mm @ 1100 nm
Input beam Ø 1/e²:	14 mm
Focus size Ø 1/e²:	50 µm @ 900 nm; 61 µm @ 1100 nm
a1 a2:	17 mm 40.5 mm
Telecentricity (only F-Theta with scanner):	16.4° 16.4°
Group delay dispersion (GDD):	621 fs²
LIDT coating pulsed; CW:	not available yet
LIDT system pulsed; CW:	not available yet
Weight:	0.66 kg
Order Number:	628951

Spot properties

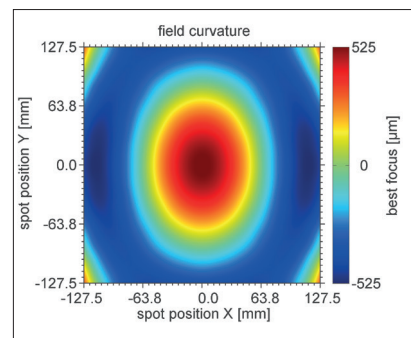
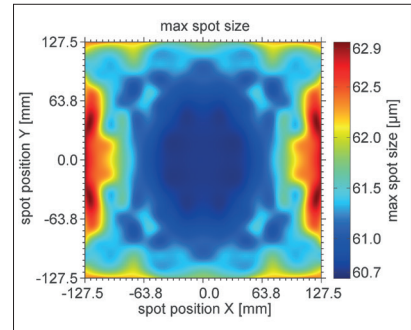

Specifications

JENar™ 423-900...1100-360

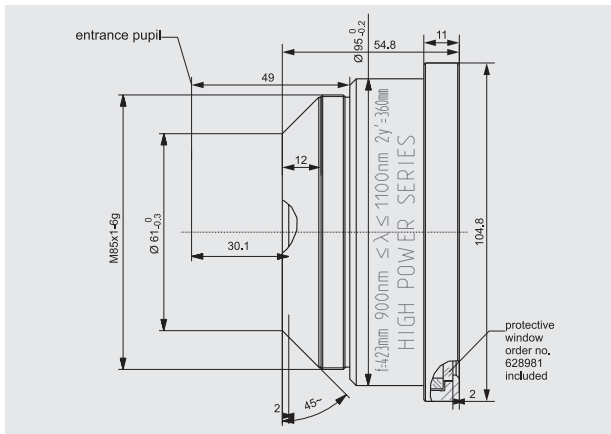

Definition of geometrical parameters

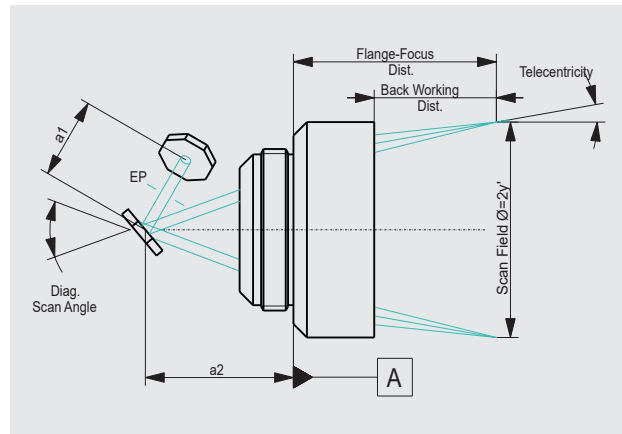

JENar™: Registered in EU, CN, JP, SG, US | Silverline™: Registered in DE, JP, SG, IN

The data given are nominal values for the specified application parameters. Jenoptik provides Zemax® BlackBox files for simulating application results for customized parameters (e.g. wavelength, scanner geometry, beam diameter, ...).
Back working distance, Flange focus distance, and focal length vary by ± 1.5 % due to manufacturing variances.

It is our policy to constantly improve the design and specifications. Accordingly, the details represented herein cannot be regarded as final and binding.

F-Theta JENar™ Silverline™ Lens

High Power Lens – JENar™ 115-515...540-71

Parameters	JENar™ 115-515...540-71 Fused silica lens for Ultrashort pulse
Focal length:	115 mm
Wavelength:	515...540 nm
Scan field (X x Y); Ø:	(50 mm x 50 mm); 71 mm
Diagonal scan angle:	± 18°
X/Y mirror angle:	± 6.4°
Back working distance:	146 mm
Flange focus distance:	196.3 mm
Input beam Ø 1/e²:	14 mm
Focus size Ø 1/e²:	8 µm
a1 a2:	17 mm 40.5 mm
Telecentricity (only F-Theta with scanner):	3.5° 3.7°
Group delay dispersion (GDD):	3216 fs²
LIDT coating pulsed; CW:	2.5 J/cm² * (τ/[ns]) ^ 0.35; 2.5 MW/cm²
LIDT system pulsed; CW:	2.5 J/cm² * (τ/[ns]) ^ 0.35; 2.5 MW/cm²
Weight:	1.014 kg
Order Number:	624103

Spot properties

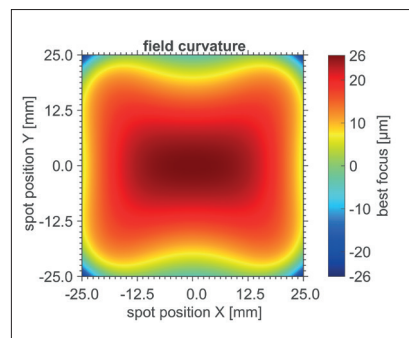
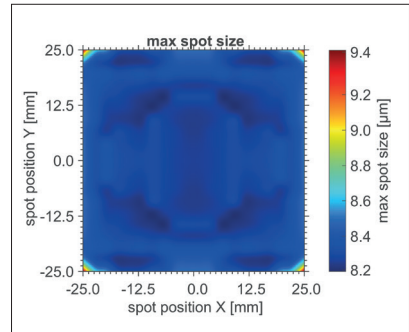

Specifications

JENar™ 115-515...540-71

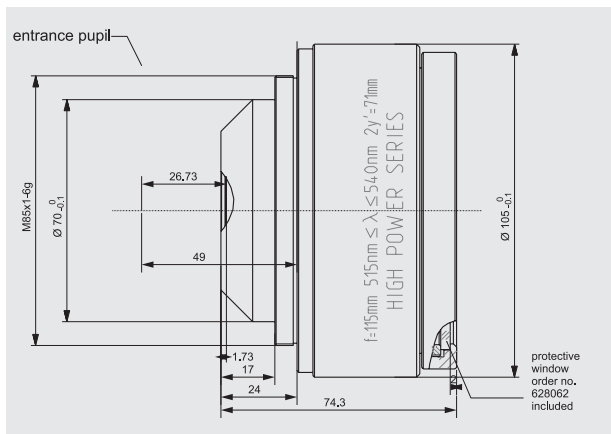

Definition of geometrical parameters

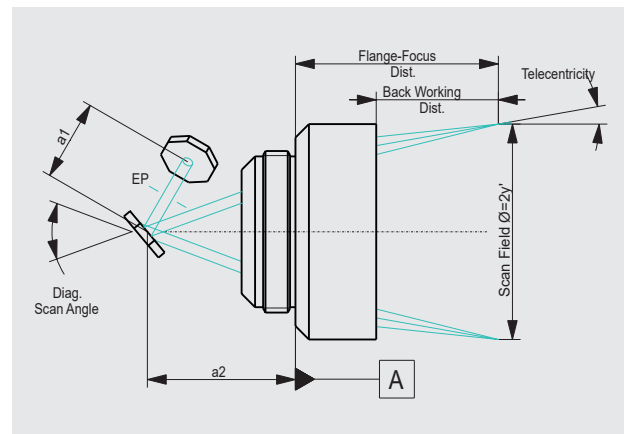

JENar™: Registered in EU, CN, JP, SG, US | Silverline™: Registered in DE, JP, SG, IN
624103: Utility patent DE 20 2018 100 368 | Utility patent pending in CN, KR

The data given are nominal values for the specified application parameters. Jenoptik provides Zemax® BlackBox files for simulating application results for customized parameters (e.g. wavelength, scanner geometry, beam diameter, ...).
Back working distance, Flange focus distance, and focal length vary by ± 1.5 % due to manufacturing variances.

It is our policy to constantly improve the design and specifications. Accordingly, the details represented herein cannot be regarded as final and binding.

F-Theta JENar™ Silverline™ Lens

High Power Lens – JENar™ 163-515...540-92

Parameters	JENar™ 163-515...540-92 Fused silica lens for Ultrashort pulse
Focal length:	163 mm
Wavelength:	515...540 nm
Scan field (X x Y); Ø:	(65 mm x 65 mm); 92 mm
Diagonal scan angle:	± 16.4°
X/Y mirror angle:	± 5.8°
Back working distance:	234.7 mm
Flange focus distance:	334.5 mm
Input beam Ø 1/e ² :	12 mm ^{A)}
Focus size Ø 1/e ² :	14 µm
a1 a2:	17 mm 49 mm
Telecentricity (only F-Theta with scanner):	0.4° 1.0°
Group delay dispersion (GDD):	4515 fs ²
LIDT coating pulsed; CW:	2.5 J/cm ² * (τ/[ns]) ^ 0.35; 2.5 MW/cm ²
LIDT system pulsed; CW:	2.5 J/cm ² * (τ/[ns]) ^ 0.35; 2.5 MW/cm ²
Weight:	2.196 kg
Order Number:	659612

Spot properties

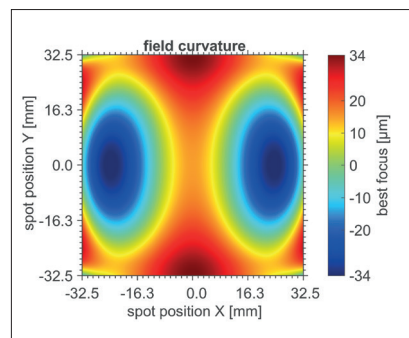
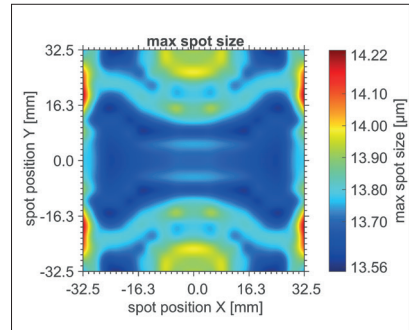

^{A)}14 mm aperture possible without vignetting

Specifications JENar™ 163-515...540-92

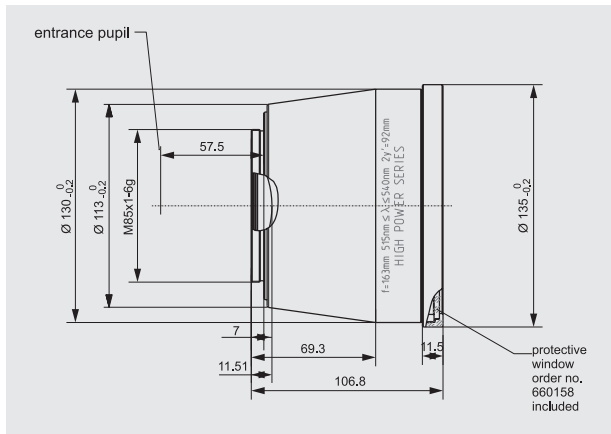

Definition of geometrical parameters

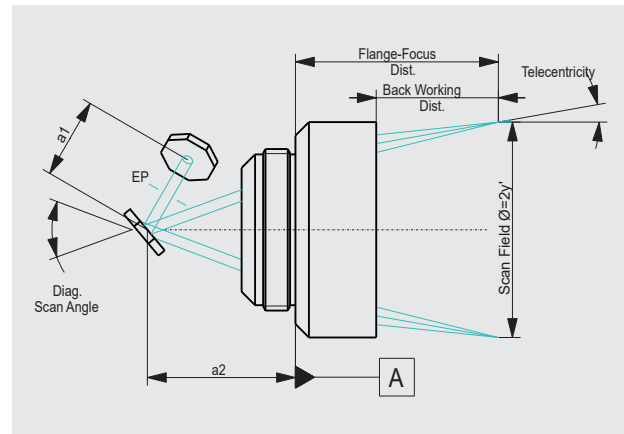

JENar™: Registered in EU, CN, JP, SG, US | Silverline™: Registered in DE, JP, SG, IN
659612: Utility patent DE 20 2020 104094.4

The data given are nominal values for the specified application parameters. Jenoptik provides Zemax® BlackBox files for simulating application results for customized parameters (e.g. wavelength, scanner geometry, beam diameter, ...).
Back working distance, Flange focus distance, and focal length vary by ± 1.5 % due to manufacturing variances.

It is our policy to constantly improve the design and specifications. Accordingly, the details represented herein cannot be regarded as final and binding.

F-Theta JENar™ Silverline™

High Power Lens – JENar™ Silverline™ 330 - 515... 540-332

Parameters	JENar™ Silverline™ 330-515...540-332 Fused silica lens
Focal length:	330 mm
Wavelength:	515...540 nm
Scan field (X x Y); Ø:	(235 mm x 235 mm); 332 mm
Diagonal scan angle:	± 27.6°
X/Y mirror angle:	± 9.97°
Back working distance:	216.0 mm
Flange focus distance:	364.4 mm
Input beam Ø 1/e ² :	16 mm
Focus size Ø 1/e ² :	21.3 µm
a1 a2:	18.8 mm 50.0 mm
Telecentricity (only F-Theta with scanner):	23.5° 23.5°
Group delay dispersion (GDD):	3919 fs ²
LIDT coating pulsed; CW:	2.5 J/cm ² * (τ/[ns]) ^ 0.35; 2.5 MW/cm ²
LIDT system pulsed; CW:	2.5 J/cm ² * (τ/[ns]) ^ 0.35; 2.5 MW/cm ²
Weight:	3.359 kg
Order Number:	663834

Spot properties

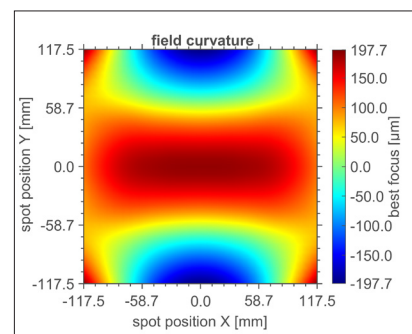
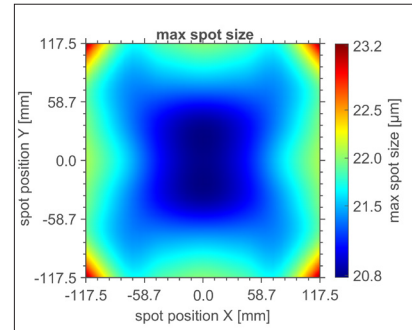

Specifications

JENar™ Silverline™ 330-515...540-332

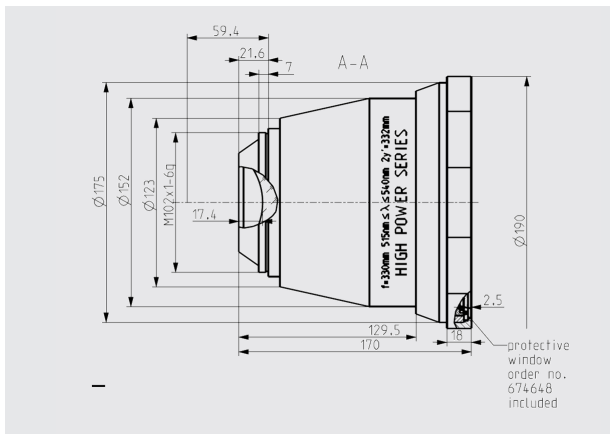

Definition of geometrical parameters

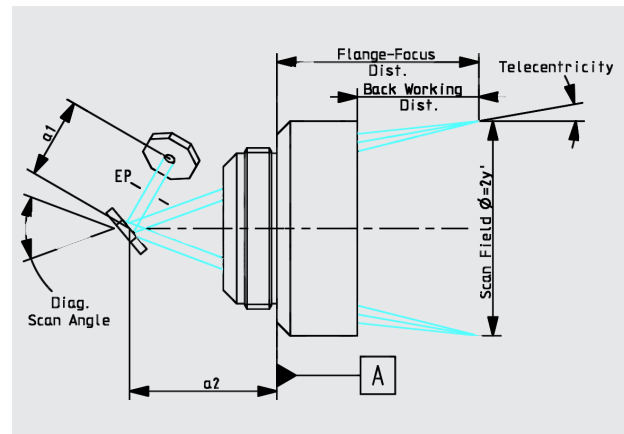

JENar™ registered in: EU, CN, JP, SG, US | Silverline™ registered in: EU, CN KR, JP, SG, IN, HK, TW

The data given are nominal values for the specified application parameters. Jenoptik provides Zemax® BlackBox files for simulating application results for customized parameters (e.g. wavelength, scanner geometry, beam diameter, ...).
Back working distance, Flange focus distance, and focal length vary by ± 1.5 % due to manufacturing variances.

It is our policy to constantly improve the design and specifications. Accordingly, the details represented herein cannot be regarded as final and binding.

F-Theta JENar™ Silverline™ Lens

High Power Lens – JENar™ 55-355-21

Parameters

JENar™ 55-355-21 Fused silica lens with different settings

Focal length:	55.8 mm	55.8 mm
Wavelength:	355 nm	355 nm
Scan field (X x Y); Ø:	(15.6 mm x 15.6 mm); 21.8 mm	(11.7 mm x 11.7 mm); 16.5 mm ¹⁾
Diagonal scan angle:	± 11.3°	± 8.5°
X/Y mirror angle:	± 4°	± 3°
Back working distance:	60.4 mm	60.4 mm
Flange focus distance:	95.3 mm	95.3 mm
Input beam Ø 1/e ² :	6 mm	8 mm
Focus size Ø 1/e ² :	6 µm	4.5 µm
a1 a2:	13 mm 46.5 mm	13 mm 46.5 mm
Telecentricity (only F-Theta with scanner):	0.83° 1.56°	0.54° 1.13°
Group delay dispersion (GDD):	4021 fs ²	4021 fs ²
LIDT coating pulsed; CW:	1.0 J/cm ² * (τ/[ns]) ^ 0.40; 1.0 MW/cm ²	1.0 J/cm ² * (τ/[ns]) ^ 0.40; 1.0 MW/cm ²
LIDT system pulsed; CW:	1.0 J/cm ² * (τ/[ns]) ^ 0.40; 1.0 MW/cm ²	1.0 J/cm ² * (τ/[ns]) ^ 0.40; 1.0 MW/cm ²
Weight:	0.57 kg	0.57 kg
Order Number:	605678	

¹⁾ 21.8 mm scanfield possible without vignetting

Lens

Spot properties JENar™ 55-355-21 | 6 mm

JENar™ 55-355-21 | 8 mm

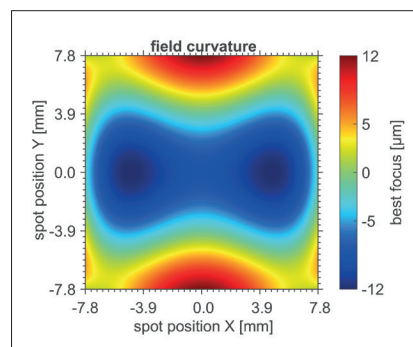
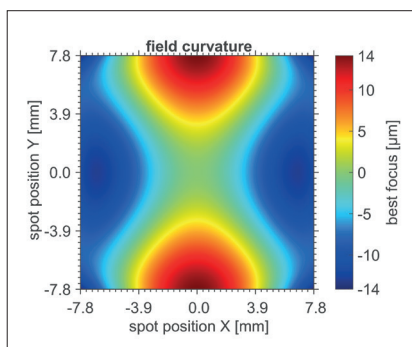
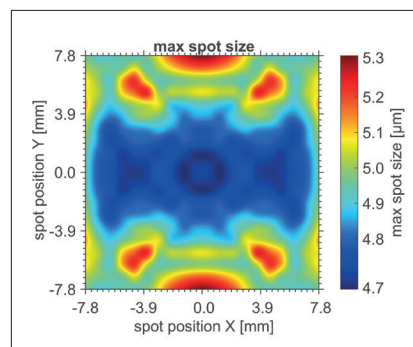
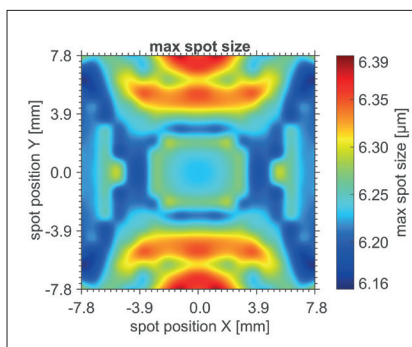

[Back to overview](#)

F-Theta JENar™ Silverline™ Lens High Power Lens – JENar™ 55-355-21

Specifications
JENar™ 55-355-21

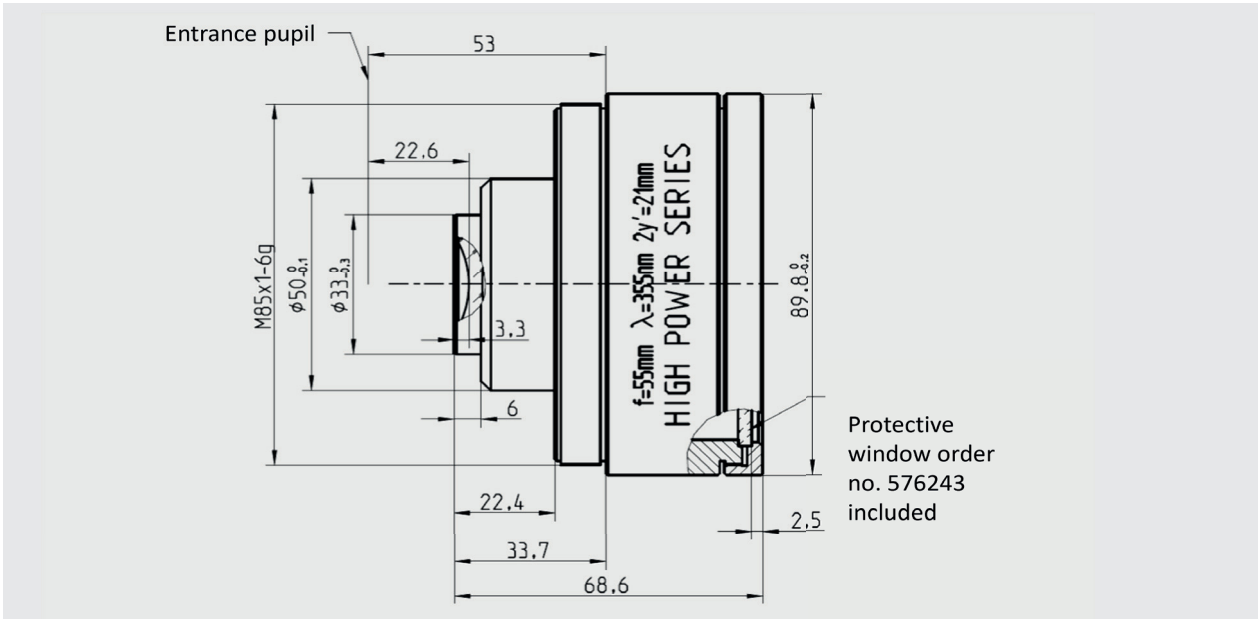

Definition of geometrical parameters

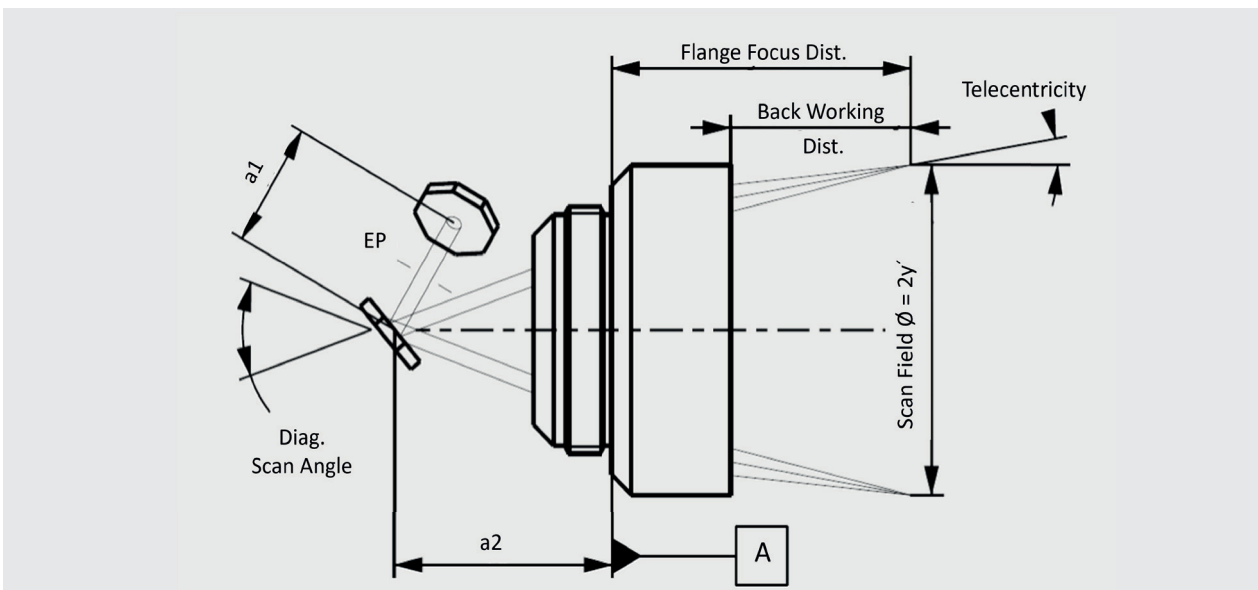

JENar®: Registered in EU, CN, JP, SG, US | Silverline®: Registered in DE, JP, SG, IN
605678: Utility patent DE 20 2018 100 369 | Utility patent in CN, pending in JP, KR

The data given are nominal values for the specified application parameters. Jenoptik provides Zemax® BlackBox files for simulating application results for customized parameters (e.g. wavelength, scanner geometry, beam diameter, ...).
Back working distance, Flange focus distance, and focal length vary by $\pm 1.5\%$ due to manufacturing variances.

It is our policy to constantly improve the design and specifications. Accordingly, the details represented herein cannot be regarded as final and binding.

F-Theta JENar™ Silverline™ Lens

High Power Lens – JENar™ 103-355-71

Parameters	JENar™ 103-355-71 Telecentric fused silica lens
Focal length:	103 mm
Wavelength:	355 nm
Scan field (X x Y); Ø:	(50 mm x 50 mm); 71 mm
Diagonal scan angle:	± 20.1°
X/Y mirror angle:	± 7.2°
Back working distance:	134.85 mm
Flange focus distance:	176.95 mm
Input beam Ø 1/e²:	9 mm
Focus size Ø 1/e²:	8 µm
a1 a2:	14 mm 46.5 mm
Telecentricity (only F-Theta with scanner):	2.4° 2.8°
Group delay dispersion (GDD):	5670 fs²
LIDT coating pulsed; CW:	1.0 J/cm² * (τ/[ns]) ^ 0.40; 1.0 MW/cm²
LIDT system pulsed; CW:	not available yet
Weight:	0.7 kg
Order Number:	017700-402-26

Spot properties

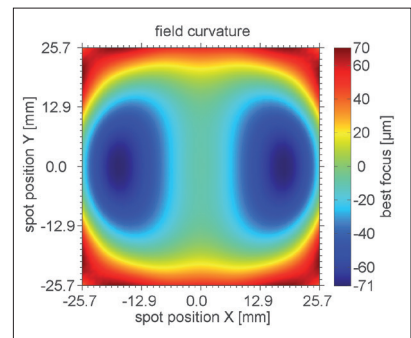
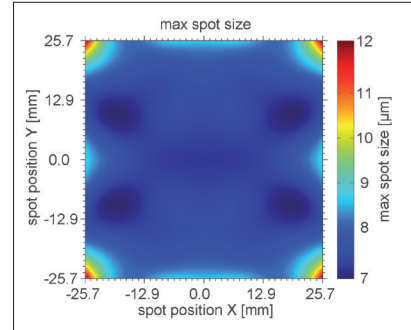

Specifications JENar™ 103-355-71

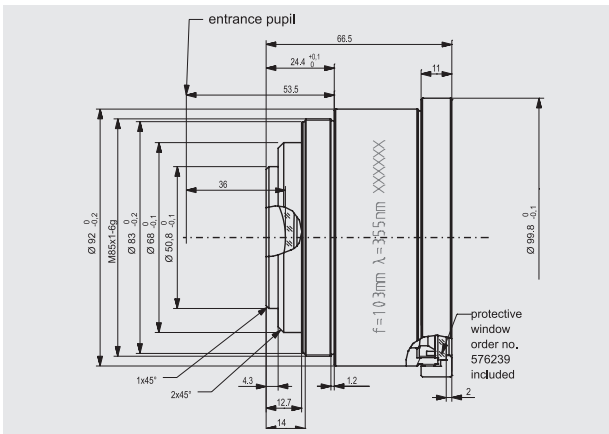

Definition of geometrical parameters

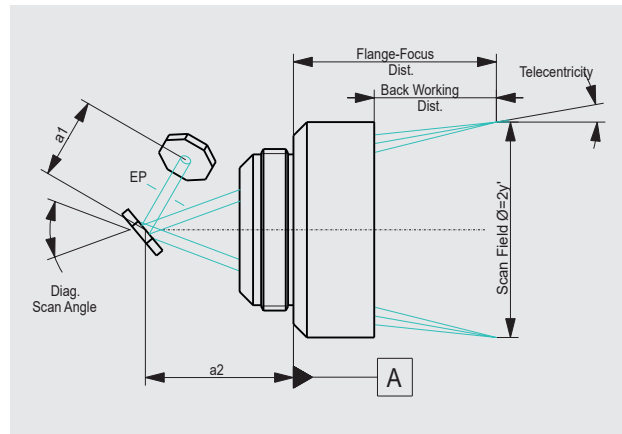

JENar™: Registered in EU, CN, JP, SG, US | Silverline™: Registered in DE, JP, SG, IN

The data given are nominal values for the specified application parameters. Jenoptik provides Zemax® BlackBox files for simulating application results for customized parameters (e.g. wavelength, scanner geometry, beam diameter, ...).
Back working distance, Flange focus distance, and focal length vary by ± 1.5 % due to manufacturing variances.

It is our policy to constantly improve the design and specifications. Accordingly, the details represented herein cannot be regarded as final and binding.

F-Theta JENar™ Silverline™ Lens High Power Lens – JENar™ 125-355-75

Parameters	JENar™ 125-355-75 Fused silica lens for Ultrashort pulse
Focal length:	125 mm
Wavelength:	355 nm
Scan field (X x Y); Ø:	(53 mm x 53 mm); 75 mm ^{B)}
Diagonal scan angle:	± 17.7°
X/Y mirror angle:	± 6.3°
Back working distance:	163.5 mm
Flange focus distance:	263.95 mm
Input beam Ø 1/e ² :	10 mm ^{B)}
Focus size Ø 1/e ² :	8 µm
a1 a2:	13 mm ^{A), B)} 42.5 mm
Telecentricity (only F-Theta with scanner):	0.01° 0.97°
Group delay dispersion (GDD)*:	7520 fs ²
LIDT coating pulsed; CW*:	1.0 J/cm ² * (τ/[ns]) ^ 0.40; 1.0 MW/cm ²
LIDT system pulsed; CW*:	1.0 J/cm ² * (τ/[ns]) ^ 0.40; 1.0 MW/cm ²
Weight:	1.494 kg
Order Number:	628956

Spot properties

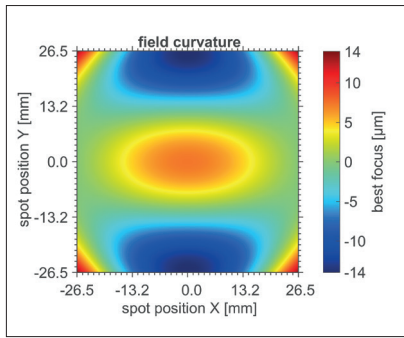
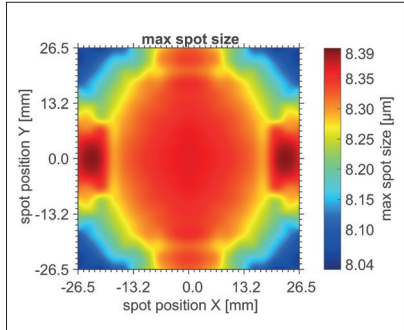

A) 10 mm aperture and a1 = 17 mm possible without vignetting
B) 14 mm aperture and a1 = 17 mm possible for 66 mm scanfield diagonale

Specifications JENar™ 125-355-75

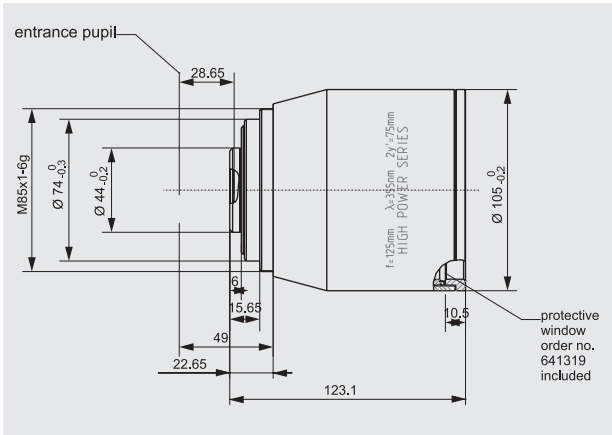

Definition of geometrical parameters

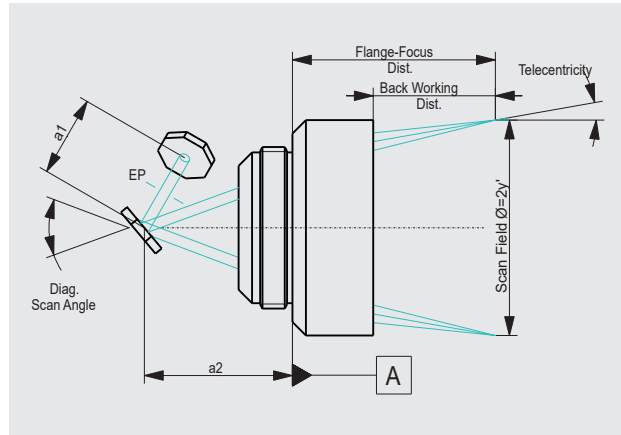

JENar™: Registered in EU, CN, JP, SG, US | Silverline™: Registered in DE, JP, SG, IN
628956: Utility patent DE 20 2019 100 632 | Utility patent pending in CN, KR

The data given are nominal values for the specified application parameters. Jenoptik provides Zemax® BlackBox files for simulating application results for customized parameters (e.g. wavelength, scanner geometry, beam diameter, ...).
Back working distance, Flange focus distance, and focal length vary by ± 1.5 % due to manufacturing variances.

It is our policy to constantly improve the design and specifications. Accordingly, the details represented herein cannot be regarded as final and binding.

F-Theta JENar™ Silverline™ Lens

High Power Lens – JENar™ 170-355-140

Parameters	JENar™ 170-355-140 Telecentric fused silica lens for large scan fields
Focal length:	170 mm
Wavelength:	355 nm
Scan field (X x Y); Ø:	(100 mm x 100 mm); 140 mm
Diagonal scan angle:	± 25°
X/Y mirror angle:	± 8.9°
Back working distance:	235.8 mm
Flange focus distance:	315.8 mm
Input beam Ø 1/e ² :	10 mm
Focus size Ø 1/e ² :	11 µm
a1 a2:	13 mm 42.5 mm
Telecentricity (only F-Theta with scanner):	4.8° 4.8°
Group delay dispersion (GDD):	8490 fs ²
LIDT coating pulsed; CW:	1.0 J/cm ² * (τ/[ns]) ^ 0.40; 1.0 MW/cm ²
LIDT system pulsed; CW:	0.5 J/cm ² * (τ/[ns]) ^ 0.40; 0.5 MW/cm ²
Weight:	1.85 kg
Order Number:	586840

Spot properties

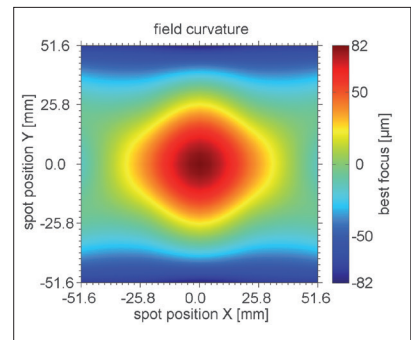
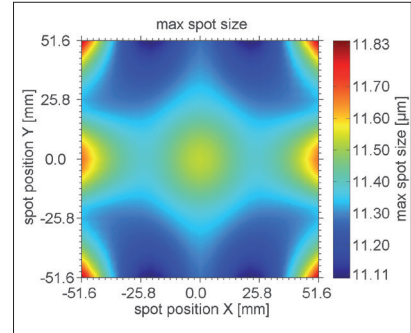

Specifications

JENar™ 170-355-140

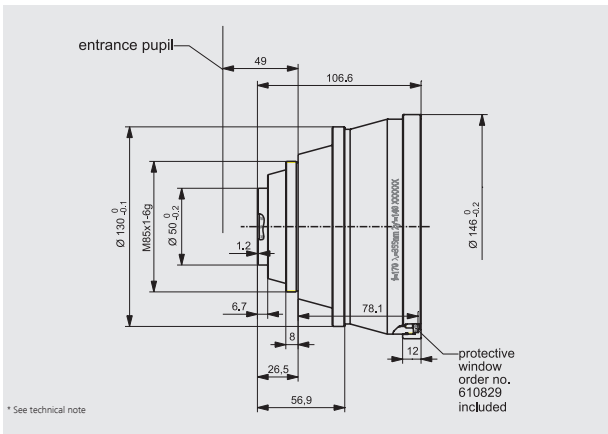

Definition of geometrical parameters

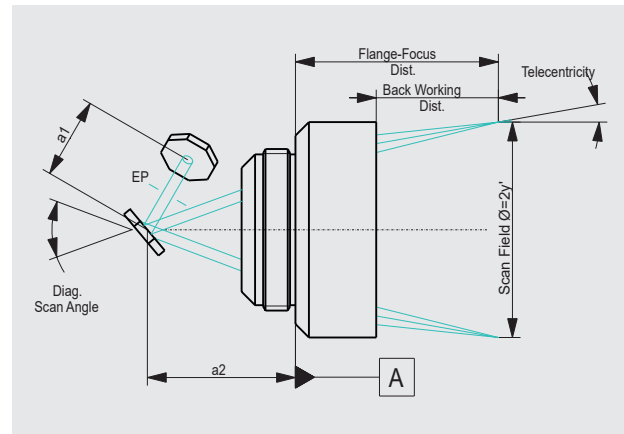

JENar™: Registered in EU, CN, JP, SG, US | Silverline™: Registered in DE, JP, SG, IN

The data given are nominal values for the specified application parameters. Jenoptik provides Zemax® BlackBox files for simulating application results for customized parameters (e.g. wavelength, scanner geometry, beam diameter, ...). Back working distance, Flange focus distance, and focal length vary by ± 1.5 % due to manufacturing variances.

It is our policy to constantly improve the design and specifications. Accordingly, the details represented herein cannot be regarded as final and binding.

F-Theta JENar™ Silverline™ Lens

High Power Lens – JENar™ 255-355-240

Parameters	JENar™ 255-355-240 Fused silica lens
Focal length:	255 mm
Wavelength:	355 nm
Scan field (X x Y); Ø:	(170 mm x 170 mm); 240 mm
Diagonal scan angle:	± 27.1°
X/Y mirror angle:	± 9.7°
Back working distance:	313.6 mm
Flange focus distance:	373.3 mm
Input beam Ø 1/e ² :	10 mm
Focus size Ø 1/e ² :	17 µm
a1 a2:	13 mm 42.5 mm
Telecentricity (only F-Theta with scanner):	12.7° 12.7°
Group delay dispersion (GDD):	6530 fs ²
LIDT coating pulsed; CW:	1.0 J/cm ² * (τ/[ns]) ^ 0.40; 1.0 MW/cm ²
LIDT system pulsed; CW:	1.0 J/cm ² * (τ/[ns]) ^ 0.40; 1.0 MW/cm ²
Weight:	1.2 kg
Order Number:	017700-406-26

Spot properties

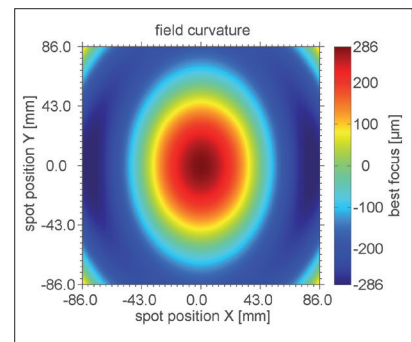
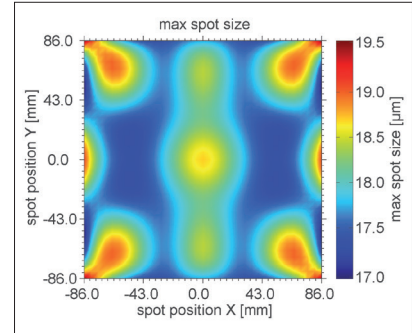

Specifications JENar™ 255-355-240

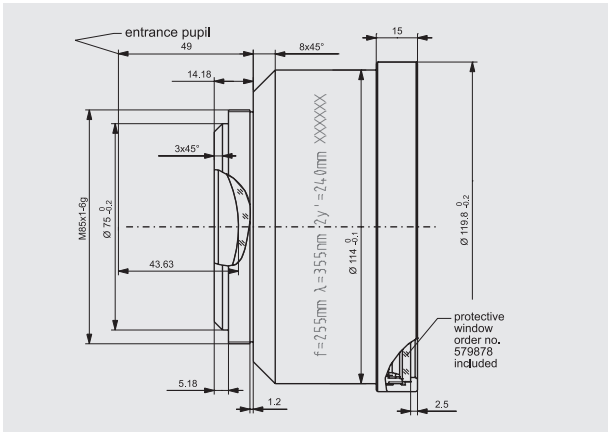

Definition of geometrical parameters

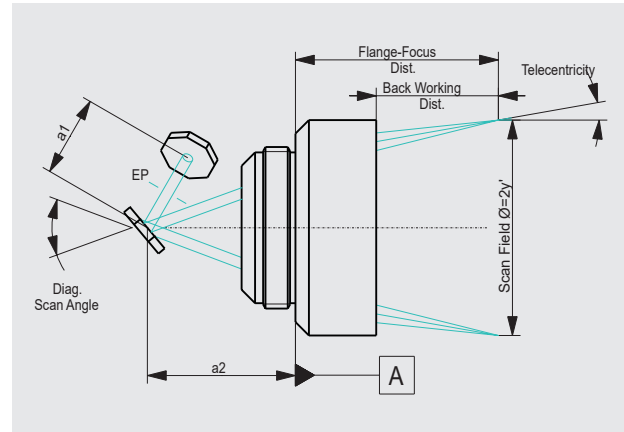

JENar™: Registered in EU, CN, JP, SG, US | Silverline™: Registered in DE, JP, SG, IN

The data given are nominal values for the specified application parameters. Jenoptik provides Zemax® BlackBox files for simulating application results for customized parameters (e.g. wavelength, scanner geometry, beam diameter, ...).
Back working distance, Flange focus distance, and focal length vary by ± 1.5 % due to manufacturing variances.

It is our policy to constantly improve the design and specifications. Accordingly, the details represented herein cannot be regarded as final and binding.

F-Theta JENar™ Silverline™ Lens

High Power Lens – JENar™ 510-355-431

Parameters	JENar™ 510-355-431 Fused silica lens for large scan fields
Focal length:	510 mm
Wavelength:	355 nm
Scan field (X x Y); Ø:	(328 mm x 328 mm); 431 mm
Diagonal scan angle:	± 25.7°
X/Y mirror angle:	± 9.2°
Back working distance:	609 mm
Flange focus distance:	637 mm
Input beam Ø 1/e ² :	14 mm
Focus size Ø 1/e ² :	24 µm
a1 a2:	14 mm 42 mm
Telecentricity (only F-Theta with scanner):	18.2° 18.2°
Group delay dispersion (GDD):	5260 fs ²
LIDT coating pulsed; CW:	1.0 J/cm ² * (τ/[ns]) ^ 0.40; 1.0 MW/cm ²
LIDT system pulsed; CW:	1.0 J/cm ² * (τ/[ns]) ^ 0.40; 1.0 MW/cm ²
Weight:	0.70 kg
Order Number:	017700-405-26

Spot properties

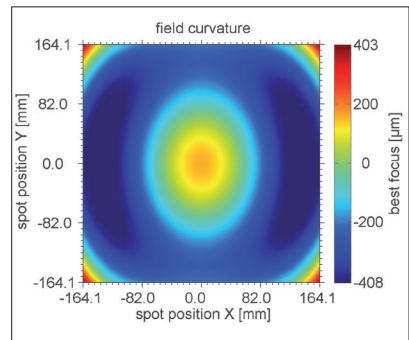
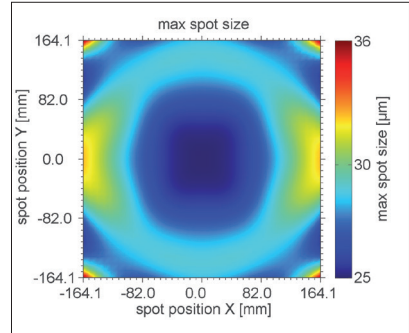

Specifications

JENar™ 510-355-431

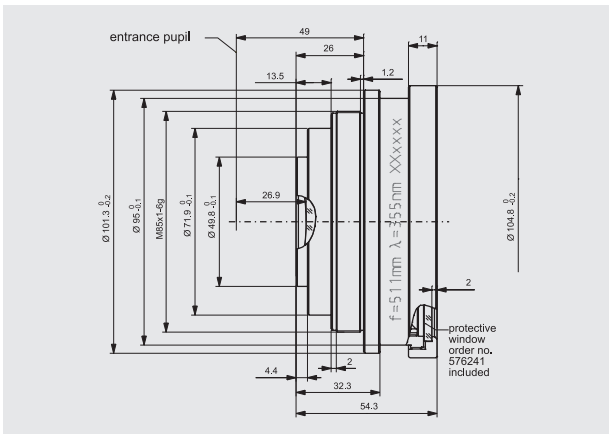

Definition of geometrical parameters

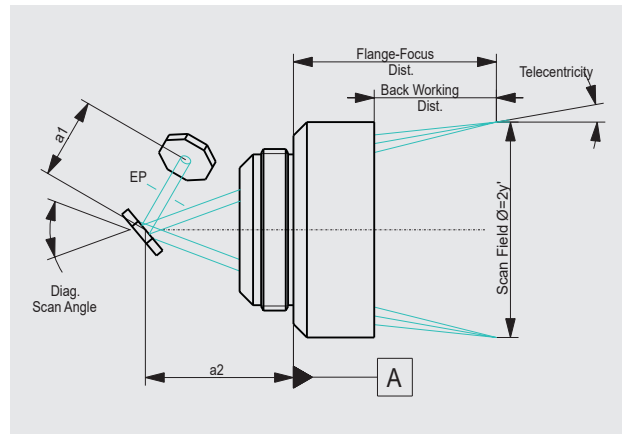

JENar™: Registered in EU, CN, JP, SG, US | Silverline™: Registered in DE, JP, SG, IN

The data given are nominal values for the specified application parameters. Jenoptik provides Zemax® BlackBox files for simulating application results for customized parameters (e.g. wavelength, scanner geometry, beam diameter, ...).
Back working distance, Flange focus distance, and focal length vary by ± 1.5 % due to manufacturing variances.

It is our policy to constantly improve the design and specifications. Accordingly, the details represented herein cannot be regarded as final and binding.

F-Theta JENar™ Silverline™ Lens High Power Lens – JENar™ 103-266-71

Parameters	JENar™ 103-266-71 Telecentric fused silica lens
Focal length:	103 mm
Wavelength:	266 nm
Scan field (X x Y); Ø:	(50 mm x 50 mm); 71 mm
Diagonal scan angle:	± 20.1°
X/Y mirror angle:	± 7.2°
Back working distance:	133 mm
Flange focus distance:	175.1 mm
Input beam Ø 1/e²:	9 mm
Focus size Ø 1/e²:	6 µm
a1 a2:	14 mm 46 mm
Telecentricity (only F-Theta with scanner):	2.6° 2.9°
Group delay dispersion (GDD):	9350 fs²
LIDT coating pulsed; CW:	not available yet
LIDT system pulsed; CW:	not available yet
Weight:	0.7 kg
Order Number:	017700-601-26

Spot properties

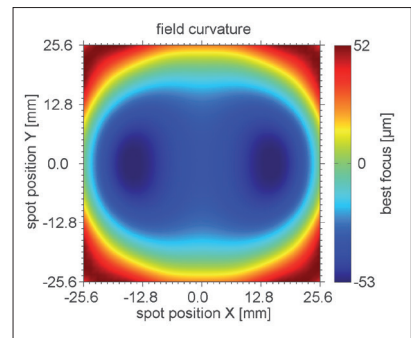
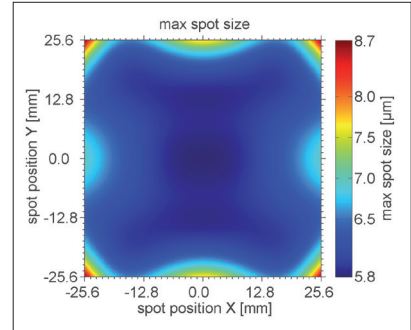

Specifications JENar™ 103-266-71

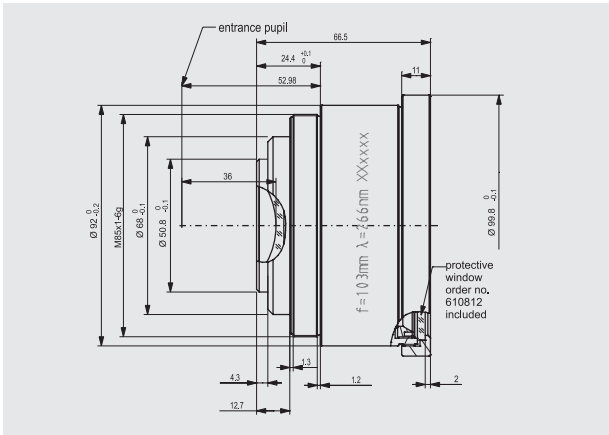

Definition of geometrical parameters

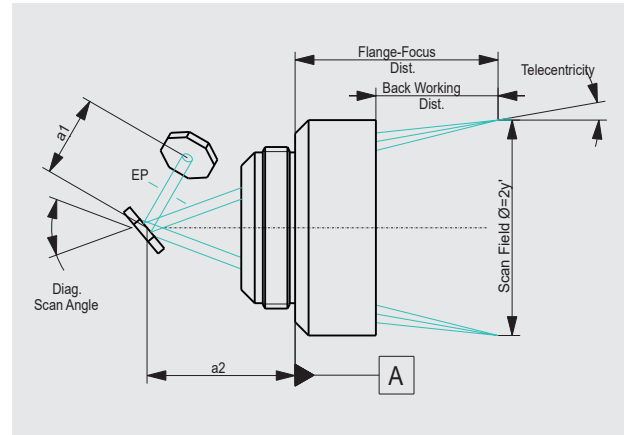

JENar™: Registered in EU, CN, JP, SG, US | Silverline™: Registered in DE, JP, SG, IN

The data given are nominal values for the specified application parameters. Jenoptik provides Zemax® BlackBox files for simulating application results for customized parameters (e.g. wavelength, scanner geometry, beam diameter, ...).
Back working distance, Flange focus distance, and focal length vary by ± 1.5 % due to manufacturing variances.

It is our policy to constantly improve the design and specifications. Accordingly, the details represented herein cannot be regarded as final and binding.

F-Theta JENar™ APTALine™ Lens

High Power Lens – JENar™ APTALine™ 160-1030...1080-110-AL

Parameters	JENar™ APTALine™ 160-1030...1080-110-AL Fused silica lens
Focal length:	160 mm
Wavelength:	1030...1080 nm
Scan field (X x Y); Ø:	(78 mm x 78 mm); 110 mm
Diagonal scan angle:	± 20°
X/Y mirror angle:	± 7.1°
Back working distance:	183.6 mm
Flange focus distance:	267.6 mm
Input beam Ø 1/e ² :	14 mm
Focus size Ø 1/e ² :	22 µm
a1 a2:	17 mm 40.5 mm
Telecentricity (only F-Theta with scanner):	5.2° 5.4°
Absorption:	fused silica: < 15 ppm/cm coating: < 25 ppm
Group delay dispersion (GDD):	759 fs ²
LIDT coating pulsed; CW:	2.5 J/cm ² * (τ/[ns]) ^ 0.30; 2.5 MW/cm ²
LIDT system pulsed; CW:	2.5 J/cm ² * (τ/[ns]) ^ 0.30; 2.5 MW/cm ²
Weight:	1.08 kg
Order Number:	689620

Spot properties

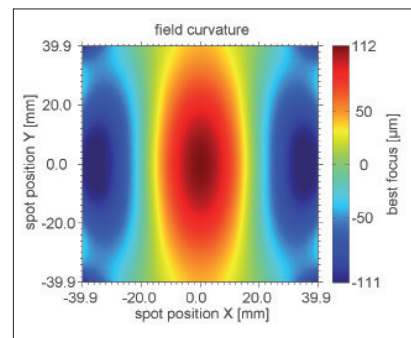
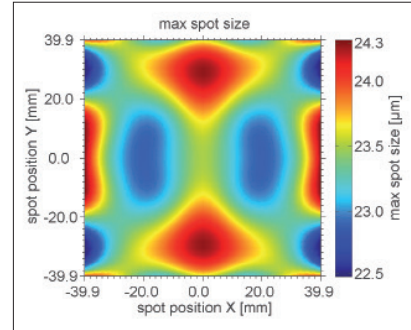

Specifications

JENar™ APTALine™160-1030...1080-110-AL

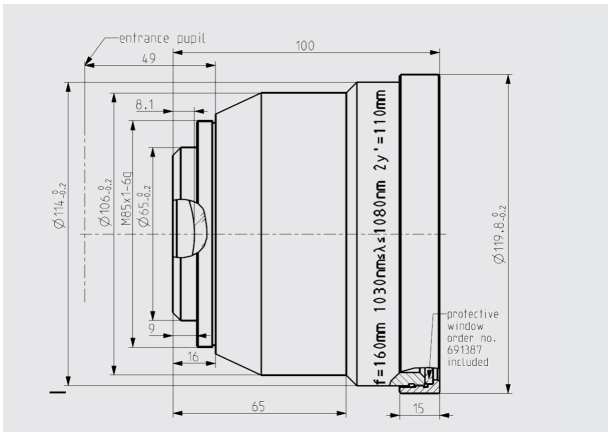

Definition of geometrical parameters

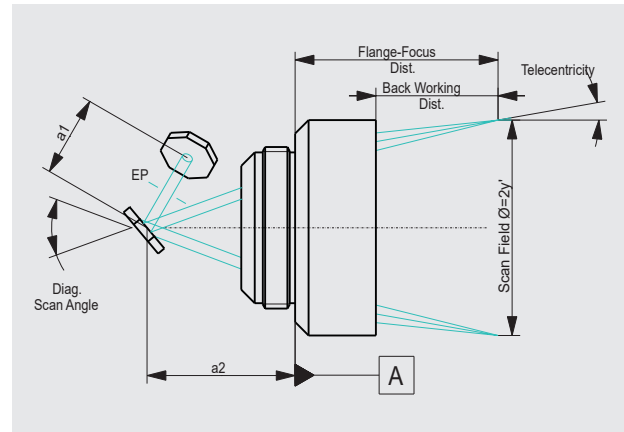

JENar™ registered in: EU, CN, JP, SG, US | F-Theta: registered in: EU, CN, KR, JP, SG, IN, HK, TW | APTALine™ registered in: DE, EU, JP, KR, US, CN

The data given are nominal values for the specified application parameters. Jenoptik provides Zemax® BlackBox files for simulating application results for customized parameters (e.g. wavelength, scanner geometry, beam diameter, ...).
Back working distance, Flange focus distance, and focal length vary by ± 1.5 % due to manufacturing variances.

It is our policy to constantly improve the design and specifications. Accordingly, the details represented herein cannot be regarded as final and binding.

F-Theta JENar™ APTAline™ Lens

High Power Lens – JENar™ APTAline™ 161-1030...1080-71-AL

Parameters	JENar™ APTAline™ 161-1030...1080-71-AL Fused silica lens
Focal length:	161 mm
Wavelength:	1030...1080 nm
Scan field (X x Y); Ø:	(50 mm x 50 mm); 71 mm
Diagonal scan angle:	± 12.7°
X/Y mirror angle:	± 4.5°
Back working distance:	153.5 mm
Flange focus distance:	254.5 mm
Input beam Ø 1/e ² :	14 mm
Focus size Ø 1/e ² :	23 µm
a1 a2:	17 mm 40.5 mm
Telecentricity (only F-Theta with scanner):	4.1° 4.2°
Absorption:	fused silica: < 15 ppm/cm coating: < 25 ppm
Group delay dispersion (GDD):	583 fs ²
LIDT coating pulsed; CW:	2.5 J/cm ² * (τ[ns]) ^ 0.3; 2.5 MW/cm ²
LIDT system pulsed; CW:	2.5 J/cm ² * (τ[ns]) ^ 0.3; 2.5 MW/cm ²
Weight:	0.917 kg
Order Number:	679781

Spot properties

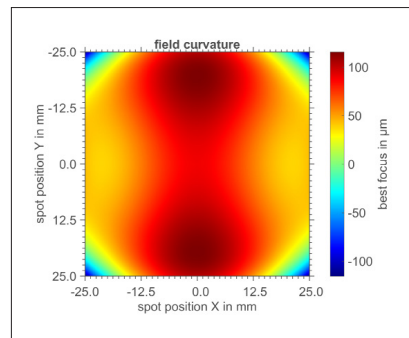
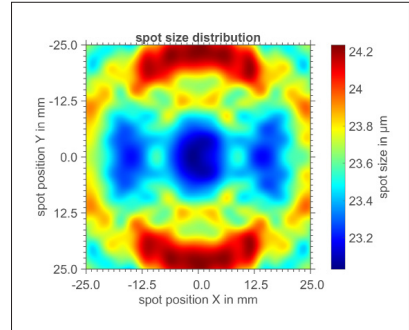

Specifications

JENar™ APTAline™ 161-1030...1080-71-AL

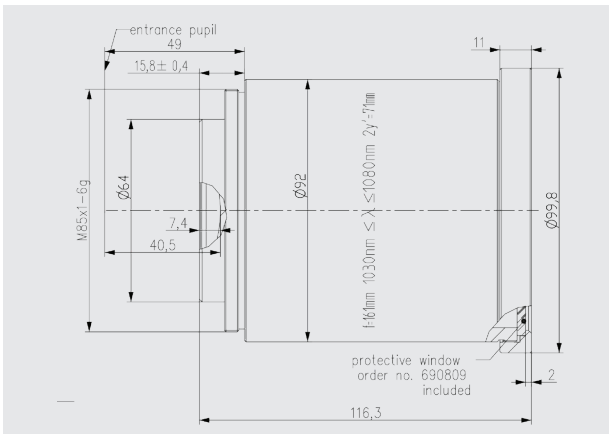

Definition of geometrical parameters

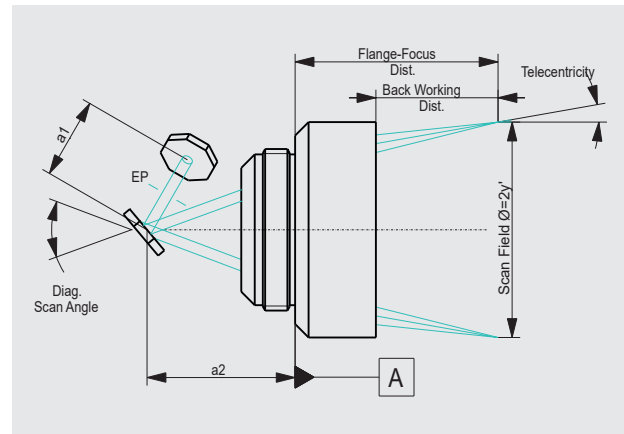

JENar™ registered in: EU, CN, JP, SG, US | F-Theta: registered in: EU, CN, KR, JP, SG, IN, HK, TW | APTAline™ registered in: DE, EU, JP, KR, US, CN

The data given are nominal values for the specified application parameters. Jenoptik provides Zemax® BlackBox files for simulating application results for customized parameters (e.g. wavelength, scanner geometry, beam diameter, ...).
Back working distance, Flange focus distance, and focal length vary by ± 1.5 % due to manufacturing variances.

It is our policy to constantly improve the design and specifications. Accordingly, the details represented herein cannot be regarded as final and binding.

F-Theta JENar™ APTALine™ Lens

High Power Lens – JENar™ APTALine™ 255-1030...1080-160-AL

Parameters	JENar™ APTALine™ 255-1030...1080-160-AL Fused silica lens
Focal length:	255 mm
Wavelength:	1030...1080 nm
Scan field (X x Y); Ø:	(114 mm x 114 mm); 160 mm
Diagonal scan angle:	± 18°
X/Y mirror angle:	± 6.4°
Back working distance:	303.3 mm
Flange focus distance:	387.8 mm
Input beam Ø 1/e ² :	20 mm
Focus size Ø 1/e ² :	25 µm
a1 a2:	25 mm 48.46 mm
Telecentricity (only F-Theta with scanner):	7.2° 7.4°
Absorption:	fused silica: < 15 ppm/cm coating: < 25 ppm
Group delay dispersion (GDD):	904 fs ²
LIDT coating pulsed; CW:	2.5 J/cm ² * (τ/[ns]) ^ 0.30; 2.5 MW/cm ²
LIDT system pulsed; CW:	2.5 J/cm ² * (τ/[ns]) ^ 0.30; 2.5 MW/cm ²
Weight:	1.2 kg
Order Number:	689622

Spot properties

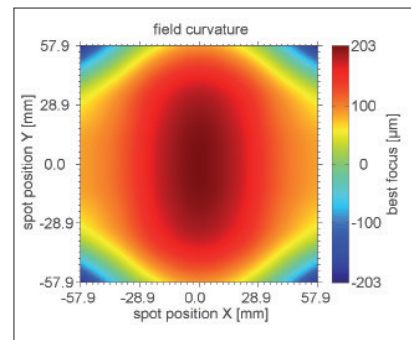
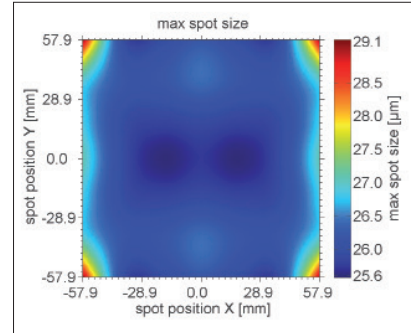

Specifications

JENar™ APTALine™ 255-1030...1080-160-AL

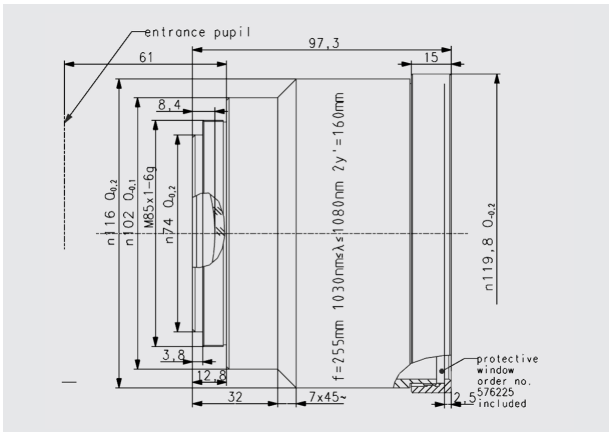

Definition of geometrical parameters

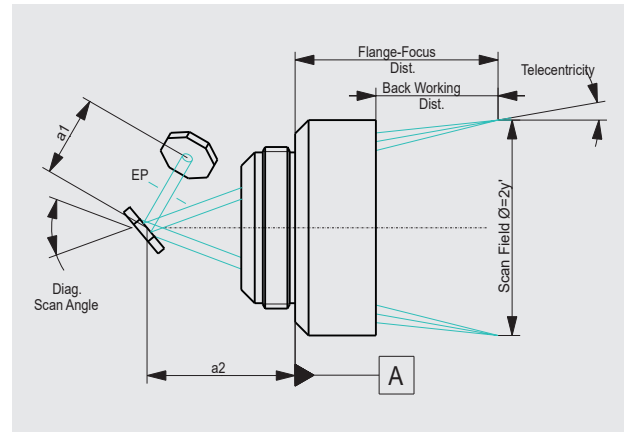

JENar™ registered in: EU, CN, JP, SG, US | F-Theta: registered in: EU, CN, KR, JP, SG, IN, HK, TW | APTALine™ registered in: DE, EU, JP, KR, US, CN

The data given are nominal values for the specified application parameters. Jenoptik provides Zemax® BlackBox files for simulating application results for customized parameters (e.g. wavelength, scanner geometry, beam diameter, ...).
Back working distance, Flange focus distance, and focal length vary by ± 1.5 % due to manufacturing variances.

It is our policy to constantly improve the design and specifications. Accordingly, the details represented herein cannot be regarded as final and binding.

F-Theta JENar™ APTAline™ Lens Series

JENar® APTAline™ 340-1030...1080-255 AL | Fused Silica Lens

Parameters	JENar™ APTAline™ 340-1030... 1080-255 AL	
Input Diameter:	20 mm*	14 mm*
Focal length:	339,6 mm	
Wavelength:	1064 nm	
Scan field (X x Y):	180 mm x 180 mm	210 mm x 210 mm
Scan field Ø:	255 mm	297 mm
Diagonal scan angle:	± 21,7°	± 25,4°
X/Y mirror angle:	± 7,6°	± 8,9°
Back working distance:	422,4 mm	422,6 mm
Flange focus distance:	484,7 mm	484,9 mm
Input beam Ø 1/e²:	20 mm	14 mm
Focus size Ø 1/e²:	34,2 µm	48,6 µm
a1:	26,0 mm	17,0 mm
a2:	36,0 mm	35,5 mm
Telecentricity (only F-Theta with scanner):	11,6° 11,6°	13,6° 13,7°
Group delay dispersion (GDD):	834 fs²	
LIDT coating pulsed; CW:	2.5 J/cm² * (τ[ns]) ^ 0.30; 2.5 MW/cm²	
LIDT system pulsed; CW:		
Weight:	1.30 kg	
Order Number:	697568	

Spot properties

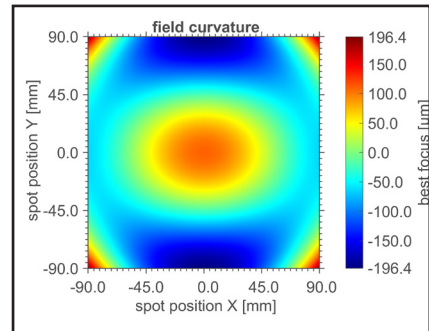
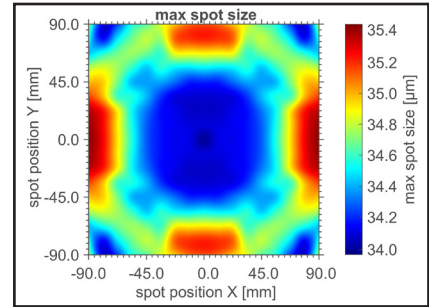

* Performance plots are show for main the application with an input beam diameter of 20 mm.

Specifications

JENar™ APTAline™ 340-1030... 1080-255 AL

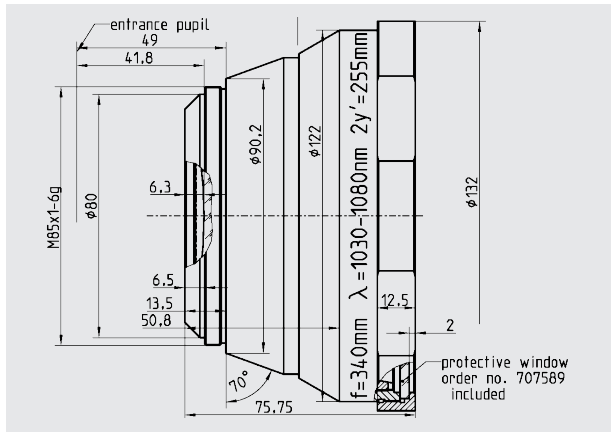

Definition of geometrical parameters

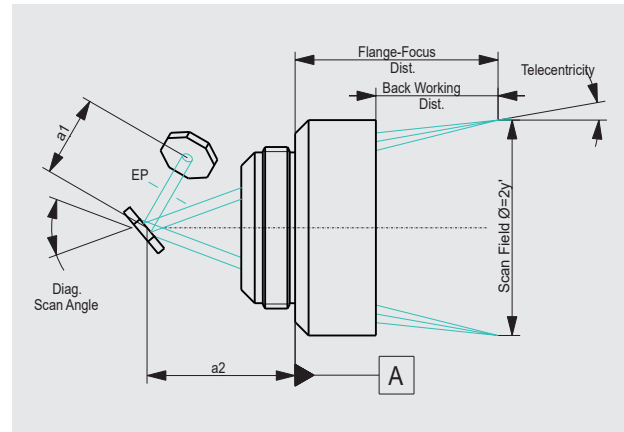

JENar™ registered in: EU, CN, JP, SG, US | F-Theta: registered in: EU, CN, KR, JP, SG, IN, HK, TW | APTAline™ registered in: DE, EU, JP, KR, US, CN

The data given are nominal values for the specified application parameters. Jenoptik provides Zemax® BlackBox files for simulating application results for customized parameters (e.g. wavelength, scanner geometry, beam diameter, ...).
Back working distance, Flange focus distance, and focal length vary by ± 1.5 % due to manufacturing variances.

It is our policy to constantly improve the design and specifications. Accordingly, the details represented herein cannot be regarded as final and binding.

F-Theta JENar™ APTAline™ Lens Series

High Image Quality – JENar™ APTAline™ 639-1030...1080-580 AL

Parameters	JENar™ APTAline™ 639-1030...1080-580 AL F-Theta lens for high image quality
Focal length:	639 mm
Wavelength:	1030...1080 nm
Scan field (X x Y); Ø:	(410 mm x 410 mm); 580 mm
Diagonal scan angle:	± 25.0°
X/Y mirror angle:	± 9°
Back working distance:	565.0 mm
Flange focus distance:	673.4 mm
Input beam Ø 1/e ² :	20.0 mm
Focus size Ø 1/e ² :	65.3 µm
a1:	25.6 mm
a2:	31.5 mm
Telecentricity (only F-Theta with scanner):	22.3° 22.4°
Group delay dispersion (GDD):	620 fs ²
LIDT coating pulsed; CW:	2.5 J/cm ² * (τ/[ns]) ^{0.3} ; 2.5 MW/cm ²
LIDT system pulsed; CW:	2.5 J/cm ² * (τ/[ns]) ^{0.3} ; 2.5 MW/cm ²
Weight:	1.875 kg
Order Number	739662*

Spot properties

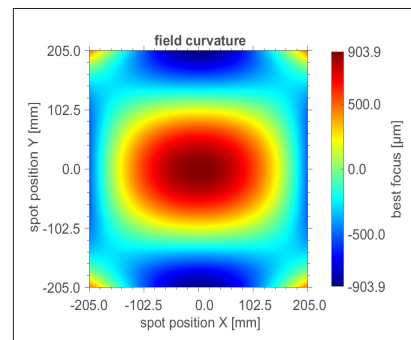
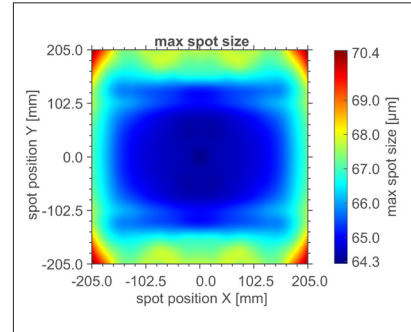

*Please note: Order number was changed. Previous one was 726577.

Specifications

JENar™ APTAline™ 639-1030...1080-580 AL

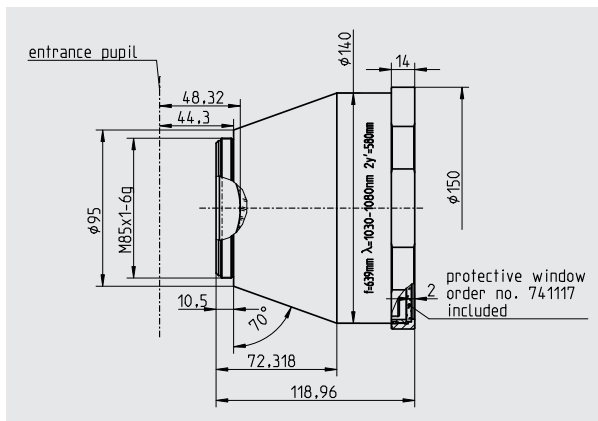

Definition of geometrical parameters

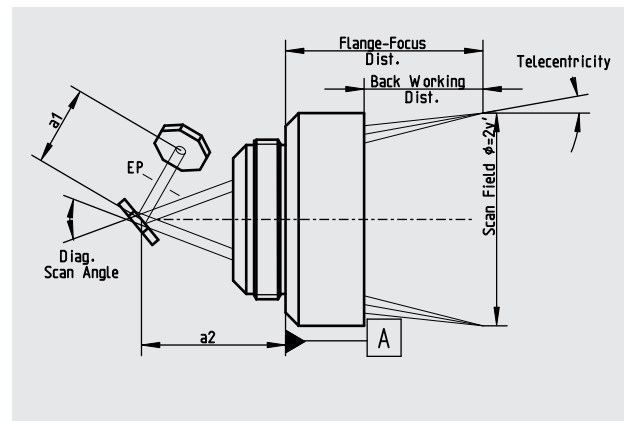

JENar®: Registered in EU, CN, JP, SG, US | F-Theta: Registered Design in EU, CN, KR, JP, SG, IN, HK, TW | APTAline® registered in: DE, EU, JP, KR, US, CN

The data given are nominal values for the specified application parameters. Jenoptik provides Zemax® BlackBox files for simulating application results for customized parameters (e.g. wavelength, scanner geometry, beam diameter, ...).
 Back working distance, Flange focus distance, and focal length vary by ± 1.5 % due to manufacturing variances.
 It is our policy to constantly improve the design and specifications. Accordingly, the details represented herein cannot be regarded as final and binding.

F-Theta JENar™ APTALin™ Lens

High Power Lens – JENar™ APTALine™ 675-1030...1080-707+VIS AL

Parameters	JENar™ APTALine™ 675-1030...1080-707+VIS AL
Focal length:	675 mm
Wavelength:	1030...1080 nm
Transmission	530nm - 1200nm T>50%
Scan field (X x Y); Ø:	(500 mm x 500 mm); 707 mm
Diagonal scan angle:	± 28.4°
XY mirror angle:	± 10.3°
Back working distance:	673.8 mm
Flange focus distance:	772.8 mm
Input beam Ø 1/e²:	14 mm
Clear aperture Ø:	20 mm
Focus size Ø 1/e²:	79.9 µm
a1:	25 mm
a2:	40.5 mm
Telecentricity (only F-Theta with scanner):	23.2° 23.2°
Group delay dispersion (GDD):	929 fs²
LIDT coating pulsed; CW:	2.5 J/cm² * (τ/[ns]) ^ 0.30; 2.5 MW/cm²
LIDT system pulsed; CW:	2.5 J/cm² * (τ/[ns]) ^ 0.30; 2.5 MW/cm²
Weight:	3.20 kg
Order Number:	666682

Spot properties

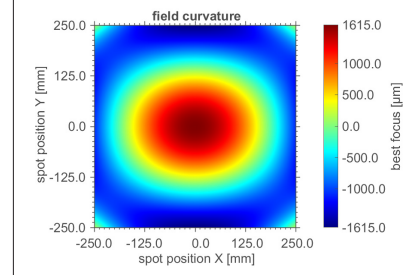
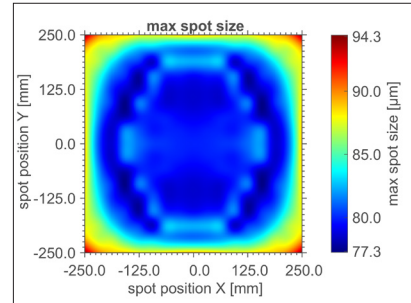

* Notification on clearance aperture:
Performance parameters/plots are for clipping the input beam at hard mechanical stop diameter of 20 mm.

Specifications

JENar™ APTALine™ 675-1030... 1080-707+VIS AL

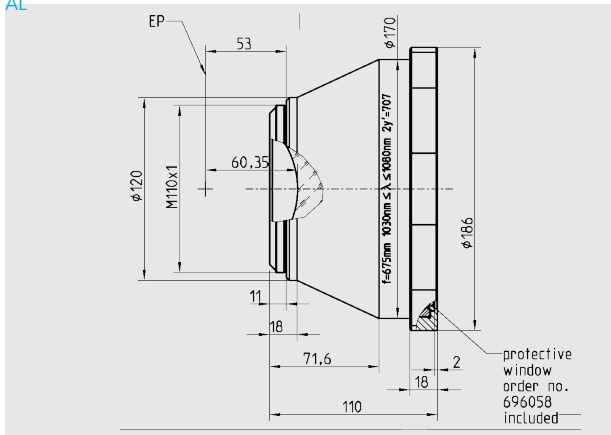

Definition of geometrical parameters

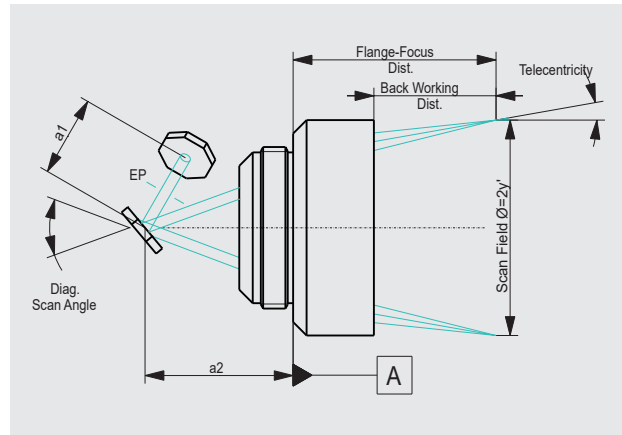

JENar™ registered in: EU, CN, JP, SG, US | F-Theta: registered in: EU, CN, KR, JP, SG, IN, HK, TW | APTALine™ registered in: DE, EU, JP, KR, US, CN

The data given are nominal values for the specified application parameters. Jenoptik provides Zemax® BlackBox files for simulating application results for customized parameters (e.g. wavelength, scanner geometry, beam diameter, ...).
Back working distance, Flange focus distance, and focal length vary by ± 1.5 % due to manufacturing variances.

It is our policy to constantly improve the design and specifications. Accordingly, the details represented herein cannot be regarded as final and binding.

F-Theta JENar™ APTAline™ Lens Series

High Image Quality – JENar™ APTAline™ 429-515...540-339 AL

Parameters	JENar™ APTAline™ 429-515...540-339 AL F-Theta lens for high image quality
Focal length:	429 mm
Wavelength:	515...540 nm
Scan field (X x Y); Ø:	(240 mm x 240 mm); 339 mm
Diagonal scan angle:	± 22.8°
X/Y mirror angle:	± 8°
Back working distance:	547.7 mm
Flange focus distance:	629.5 mm
Input beam Ø 1/e ² :	16.0 mm
Focus size Ø 1/e ² :	26.9 µm
a1:	17.00 mm
a2:	32.51 mm
Telecentricity (only F-Theta with scanner):	12.4° 12.4°
Group delay dispersion (GDD):	3328 fs ²
LIDT coating pulsed; CW:	1.25 J/cm ² * (τ/[ns]) ^{0.35} ; 1.25 MW/cm ²
LIDT system pulsed; CW:	1.25 J/cm ² * (τ/[ns]) ^{0.35} ; 1.25 MW/cm ²
Weight:	1.5 kg
Order Number	739668*

Spot properties

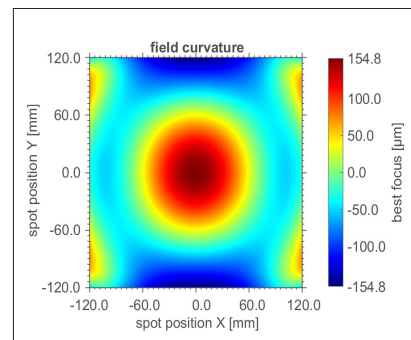
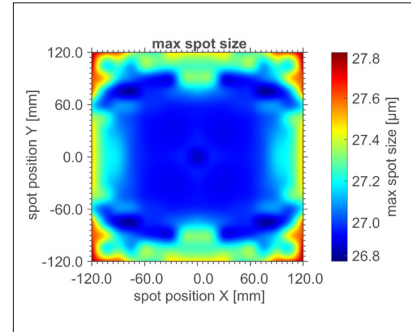

*Please note: Order number was changed. Previous one was 728095.

Specifications

JENar™ APTAline™ 429-515...540-339 AL

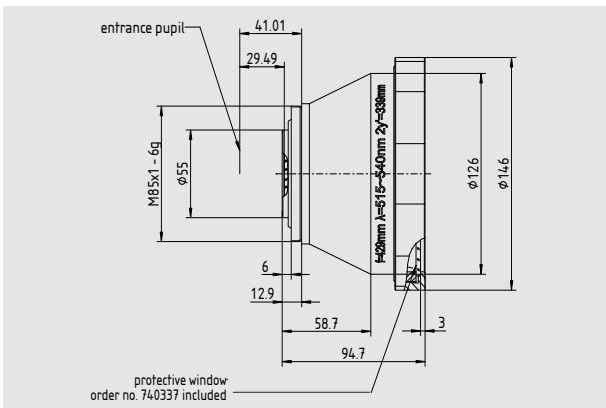

Definition of geometrical parameters

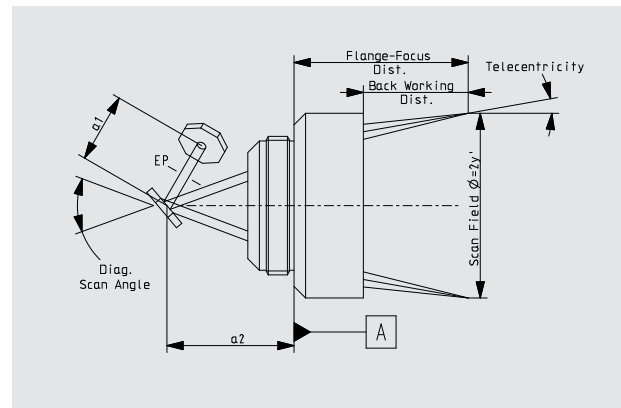

JENar®: Registered in EU, CN, JP, SG, US | F-Theta: Registered Design in EU, CN, KR, JP, SG, IN, HK, TW | APTAline® registered in: DE, EU, JP, KR, US, CN

The data given are nominal values for the specified application parameters. Jenoptik provides Zemax® BlackBox files for simulating application results for customized parameters (e.g. wavelength, scanner geometry, beam diameter, ...).
Back working distance, Flange focus distance, and focal length vary by ± 1.5 % due to manufacturing variances.

It is our policy to constantly improve the design and specifications. Accordingly, the details represented herein cannot be regarded as final

F-Theta JENar™ APTALine™ 103-355-71-AL | Fused Silica Lens

Parameters

JENar® APTALine® 103-355-71-AL Fused Silica Lens	
Focal length Wavelength	103 mm 355 nm
Scan field (X x Y); Ø	(50 mm x 50 mm); 71 mm
Diagonal scan angle X/Y mirror angle	± 20.1° ± 7.2°
Back working distance	134.85 mm
Flange focus distance	176.95 mm
Input beam Ø 1/e ² Focus size Ø 1/e ²	9 mm 8 µm
a1 a2	14 mm 46.5 mm
Telecentricity (only F-Theta with scanner)	2.4° 2.8°
Group delay dispersion (GDD)	5670 fs ²
LIDT coating pulsed; CW LIDT system pulsed; CW	0.8 J/cm ² * (τ/[ns]) ^ 0.40; 0.8 MW/cm ² 0.8 J/cm ² * (τ/[ns]) ^ 0.40; 0.8 MW/cm ²
Weight	0.7 kg
Order Number	689627

JENar™ registered in: EU, CN, JP, SG, US | F-Theta: registered in: EU, CN, KR, JP, SG, IN, HK, TW | APTALine™ registered in: DE, EU, JP, KR, US, CN

The data given are nominal values for the specified application parameters. Jenoptik provides Zemax® BlackBox files for simulating application results for customized parameters (e.g. wavelength, scanner geometry, beam diameter, ...). Back working distance, Flange focus distance, and focal length vary by ± 1.5 % due to manufacturing variances. It is our policy to constantly improve the design and specifications. Accordingly, the details represented herein cannot be regarded as final and binding.

Specifications

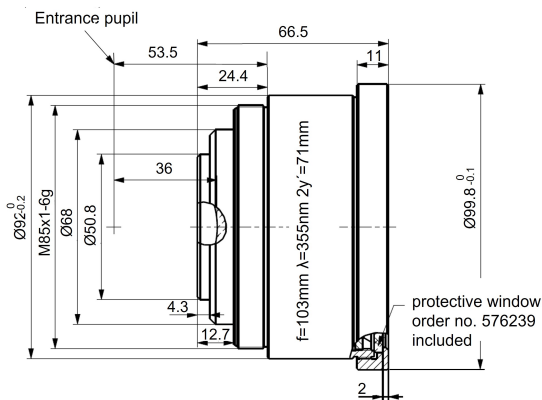

Definition of parameters

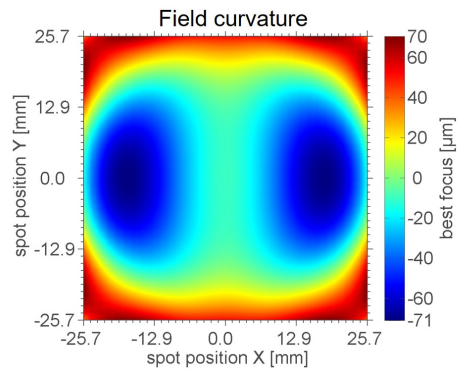
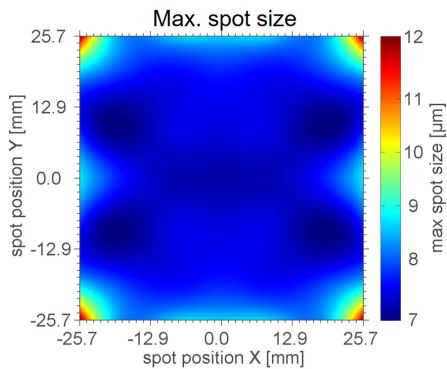
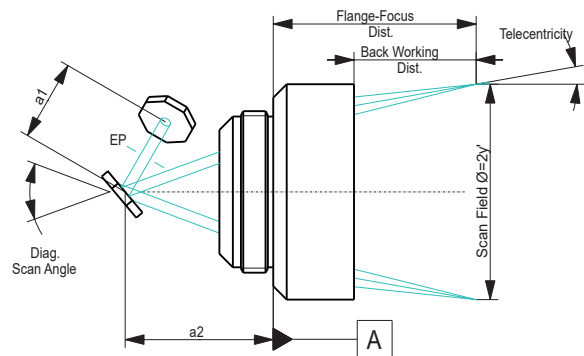

F-Theta JENar® APTAline® Lens Series

JENar® APTAline® 340-355-332 L | Fused Silica Lens

Parameters	JENar® APTAline® 340-355-332 L
Input Diameter:	20 mm
Focal length:	340 mm
Wavelength:	355 nm
Scan field (X x Y):	235 mm x 235 mm
Scan field Ø:	332 mm
Diagonal scan angle:	± 27.0°
X/Y mirror angle:	± 9.7°
Back working distance:	181.5 mm
Flange focus distance:	423.3 mm
Input beam Ø 1/e ² :	20 mm
Focus size Ø 1/e ² :	11.8 µm
a1:	26,6 mm
a2:	46.2 mm
Telecentricity (only F-Theta with scanner):	21,6° 21.7°
Group delay dispersion (GDD):	10781 fs ²
LIDT coating pulsed; CW:	t.b.d.
LIDT system pulsed; CW:	t.b.d.
Weight:	8.7 kg
Order Number:	663832

Spot properties

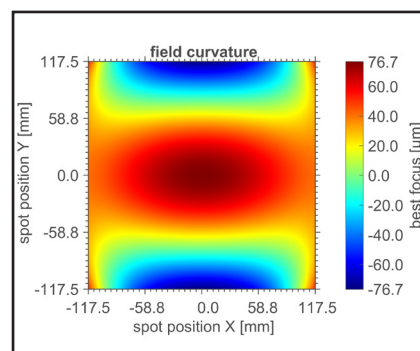
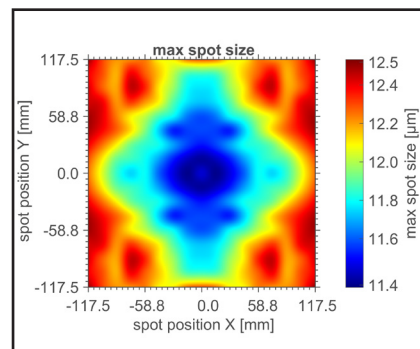

Specifications

JENar® APTAline® 340-355-332 L

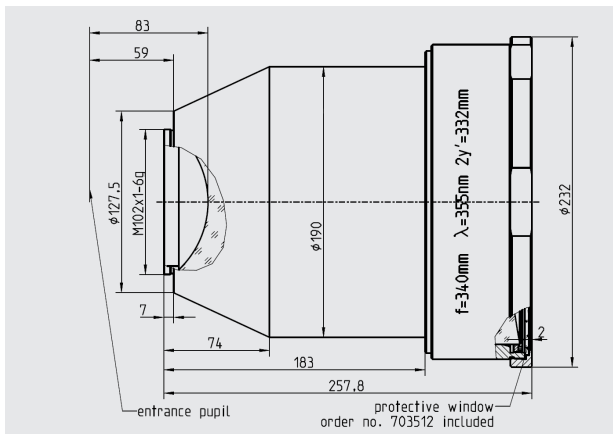

Definition of geometrical parameters

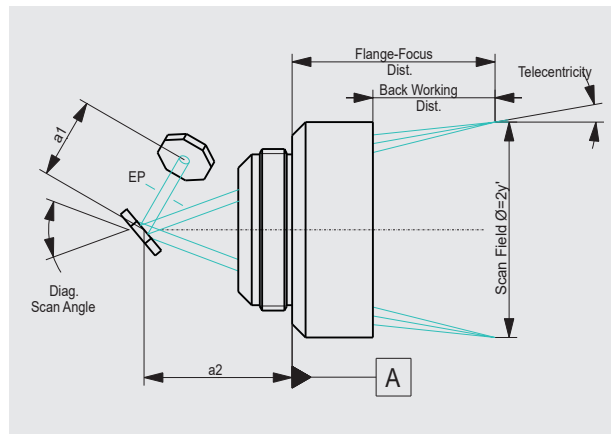

JENar™ registered in: EU, CN, JP, SG, US | F-Theta: registered in: EU, CN, KR, JP, SG, IN, HK, TW | APTAline™ registered in: DE, EU, JP, KR, US, CN

The data given are nominal values for the specified application parameters. Jenoptik provides Zemax® BlackBox files for simulating application results for customized parameters (e.g. wavelength, scanner geometry, beam diameter, ...).
Back working distance, Flange focus distance, and focal length vary by ± 1.5 % due to manufacturing variances.

It is our policy to constantly improve the design and specifications. Accordingly, the details represented herein cannot be regarded as final and binding.

F-Theta JENar™ APTALine™ Lens

High-Power Lens JENar™ APTALine™ 420-355-353-AL

Parameters	JENar APTALine™ 420-355-353-AL Fused silica lens
Focal length:	420 mm
Wavelength:	355 nm
Scan field (X x Y); Ø:	(250 mm x 250 mm); 353 mm
Diagonal scan angle:	± 24.0°
X/Y mirror angle:	± 8.5°
Back working distance:	496.0 mm
Flange focus distance:	572.0 mm
Input beam Ø 1/e ² :	15 mm
Focus size Ø 1/e ² :	18.9 µm
a1	17 mm
a2	35.1 mm
Telecentricity (only F-Theta with scanner):	14.7° 14.7°
Group delay dispersion (GDD):	6530 fs ²
LIDT coating pulsed; CW:	0.5 J/cm ² * (τ/[ns]) ^ 0.4; 0.5 MW/cm ²
LIDT system pulsed; CW:	0.5 J/cm ² * (τ/[ns]) ^ 0.4; 0.5 MW/cm ²
Weight:	1.4 kg
Order Number:	739569*

Spot properties

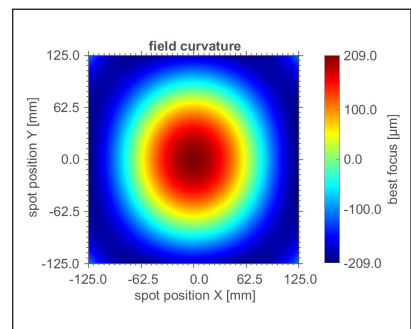
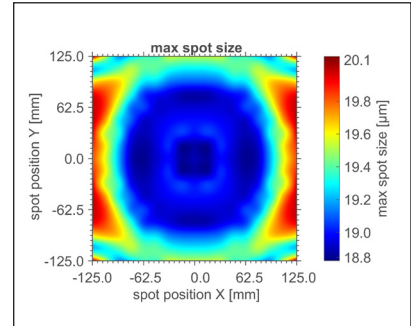

*Please note: Order number was changed. Previous one was 727640.

Specifications

JENar™ APTALine™ 420-355-353-AL

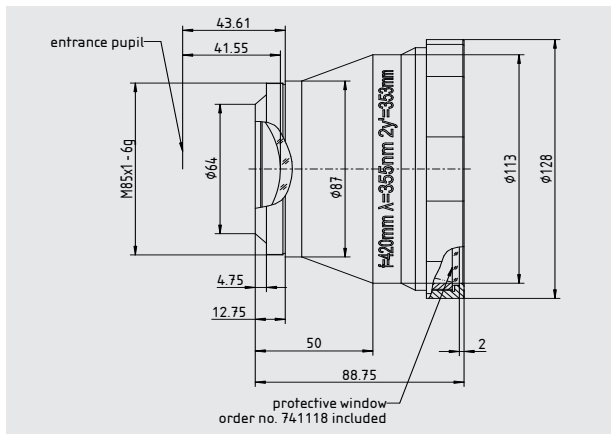

Definition of geometrical parameters

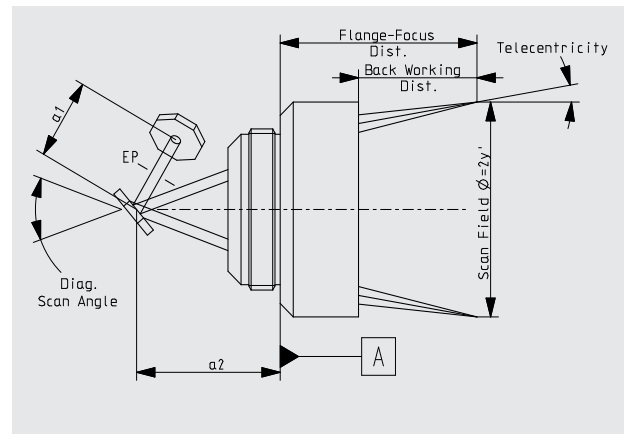

JENar® registered in: EU, CN, JP, SG, US | F-Theta registered Design in: EU, CN, KR, JP, SG, IN, HK, TW | APTALine® registered in: DE, EU, JP, KR, US, CN

The data given are nominal values for the specified application parameters. Jenoptik provides Zemax® BlackBox files for simulating application results for customized parameters (e.g. wavelength, scanner geometry, beam diameter, ...).
Back working distance, Flange focus distance, and focal length vary by ± 1.5 % due to manufacturing variances.